

www.himmel.de

Pos.	Menge	Einheit	Benennung	Sachnummer / Norm-Kurzbezeichnung	Bemerkung
				Oberfläche	Maßstab 1:20
				Position	Menge
				Datum	Name
				Bearb. 14.09.04	Schumacher
				Gepr.	
				Norm	
				HIMEL Maschinen GmbH & Co. KG Mittelhofen 11 72393 Burladingen 7 Telefon: 07126/92994-0 Telefax: 07126/9299-1	
				Horizontalmischer HOM 3	
				0002088	
				Blatt	
				Bl.	
Zust.	Änderung	Datum	Name	EDV Nr.	

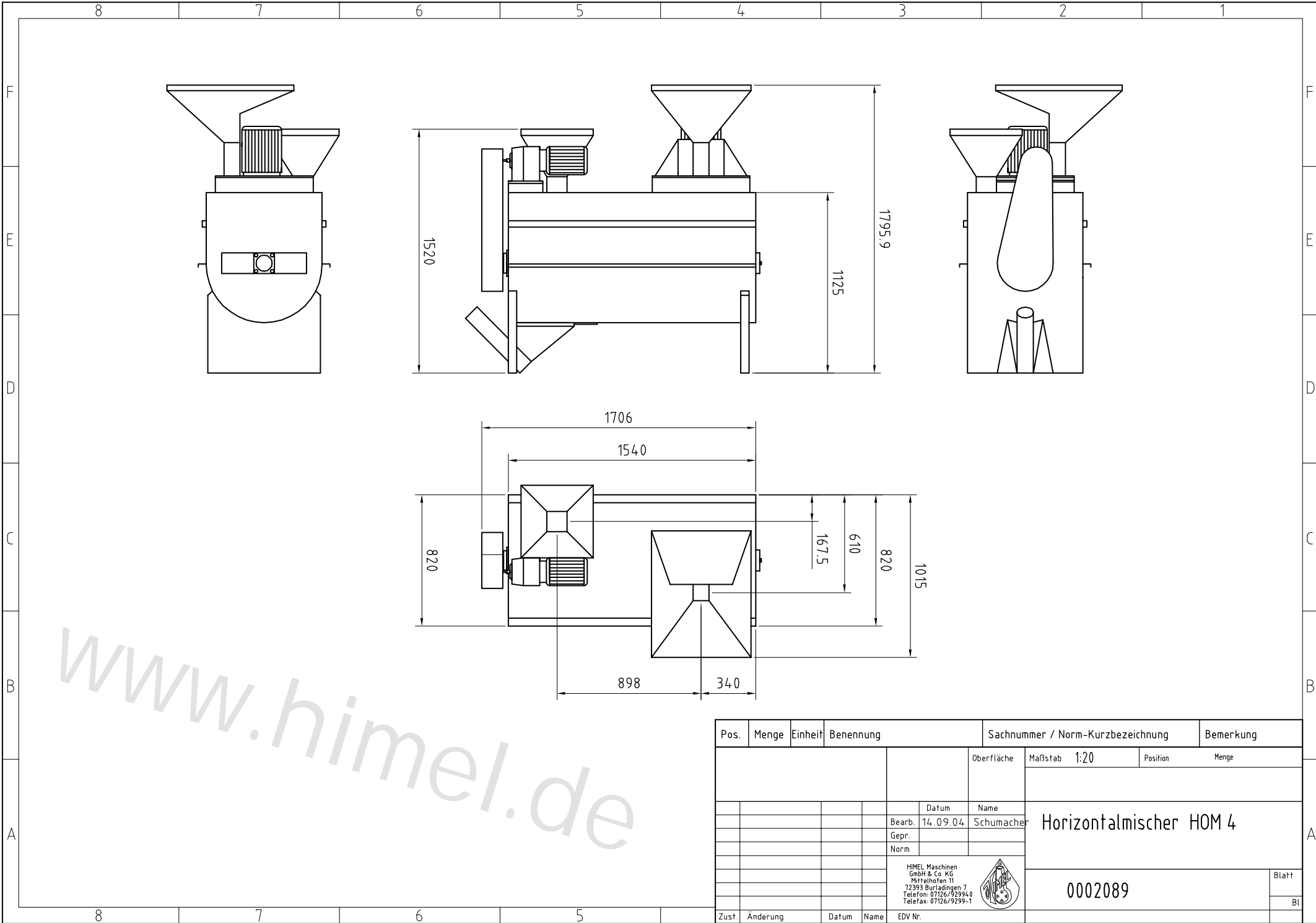

www.himmel.de

Pos.	Menge	Einheit	Benennung	Sachnummer / Norm-Kurzbezeichnung	Bemerkung
				Oberfläche	Maßstab 1:20
				Datum	Name
				Bearb. 14.09.04	Schumacher
				Gepr.	
				Norm	
				HIMEL Maschinen GmbH & Co. KG Mittelhofen 11 72393 Burladingen 7 Telefon: 07126/92994-0 Telefax: 07126/9299-1	
				Horizontalmischer HOM 4	
				0002089	
				Blatt	
				Bl	
Zust.	Änderung	Datum	Name	EDV Nr.	

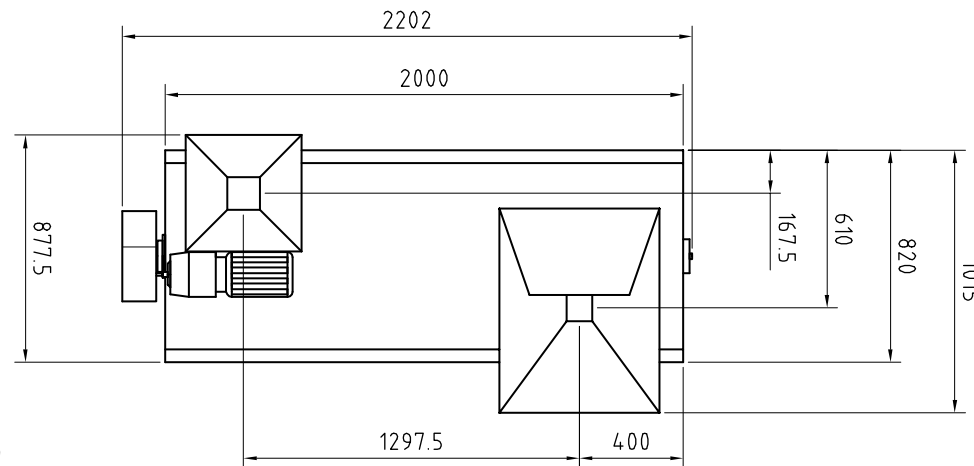
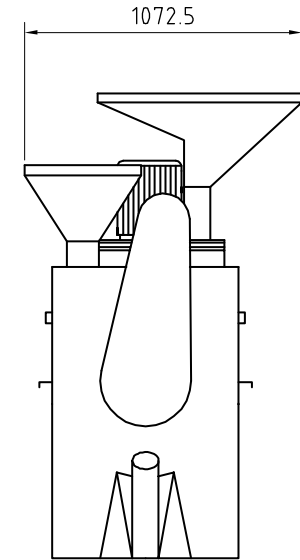
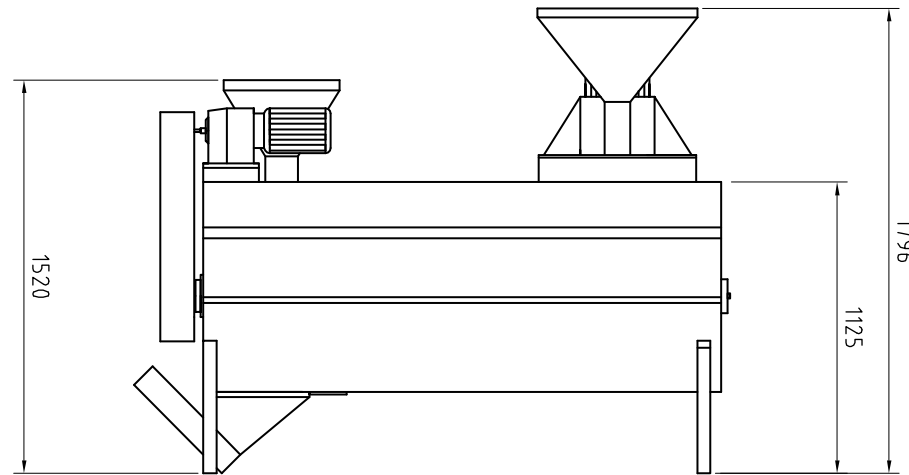
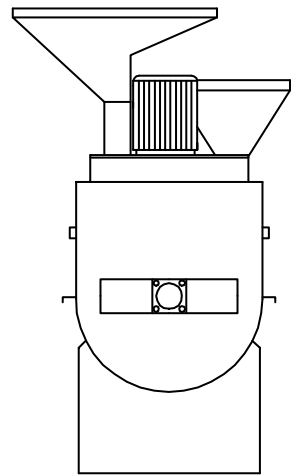

www.himmel.de

Pos.	Menge	Einheit	Benennung	Sachnummer / Norm-Kurzbezeichnung	Bemerkung
				Oberfläche	Maßstab 1:20
				Datum	Name
				Bearb. 14.09.04	Schumacher
				Gepr.	
				Norm	
				Horizontalmischer HOM 5	
				0002090	
				Blatt	
				Bl	
Zust.	Änderung	Datum	Name	EDV Nr.	



HIMEL Maschinen  
GmbH & Co. KG  
Mittelhofen 11  
72393 Burladingen 7  
Telefon: 07126/929940  
Telefax: 07126/9299-1

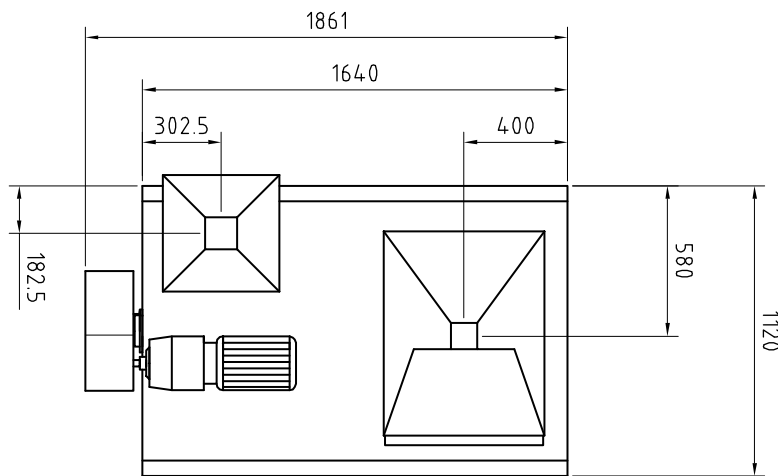
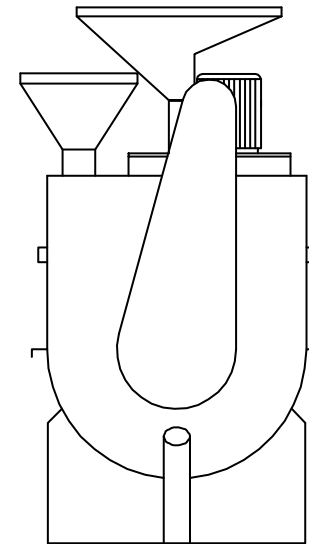
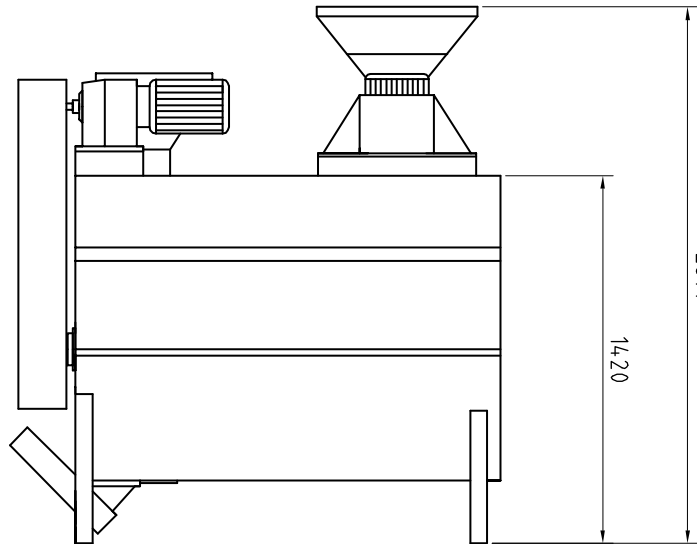
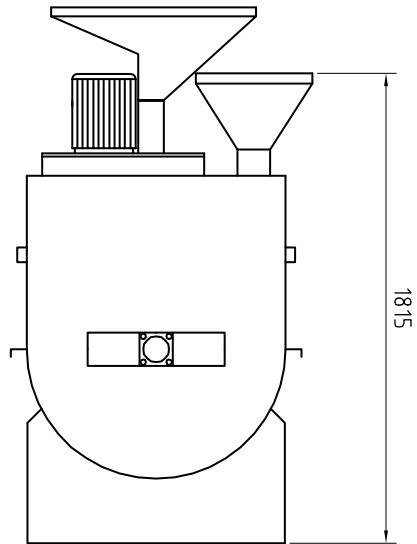

www.himmel.de

Pos.	Menge	Einheit	Benennung	Sachnummer / Norm-Kurzbezeichnung		Bemerkung
				Oberfläche	Maßstab 1:20	Position Menge
				Datum	Name	Horizontalmischer HOM 8
				Bearb. 14.09.04	Schumacher	
				Gepr.		
				Norm		
				HIMEL Maschinen GmbH & Co. KG Mittelhofen 11 72393 Burladingen 7 Telefon: 07126/929940 Telefax: 07126/9299-1		Blatt
						0002091
						Bl
Zust.	Änderung		Datum	Name	EDV Nr.	

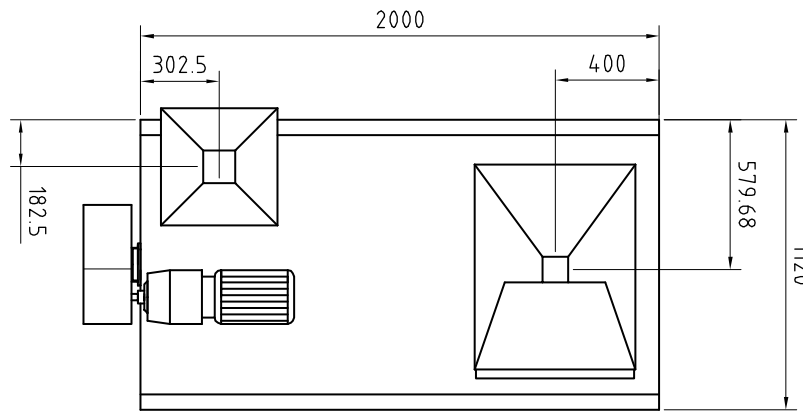
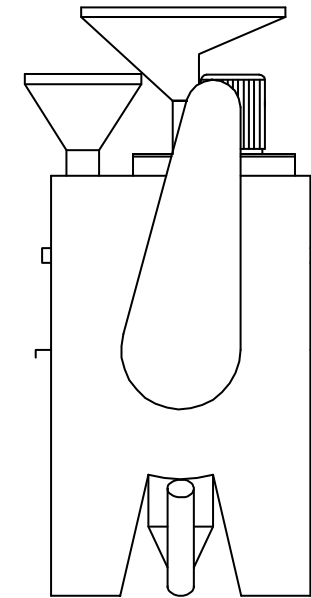
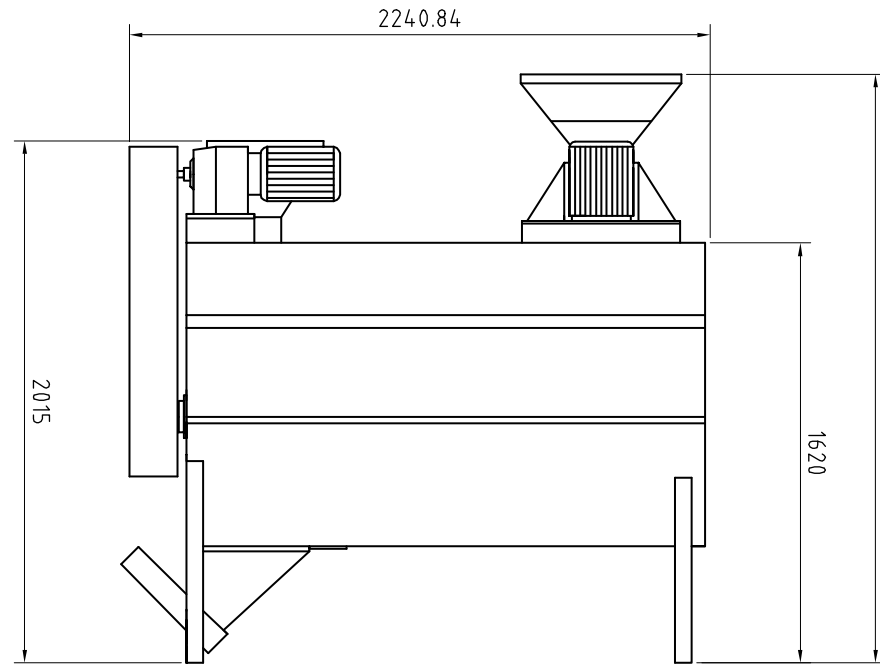
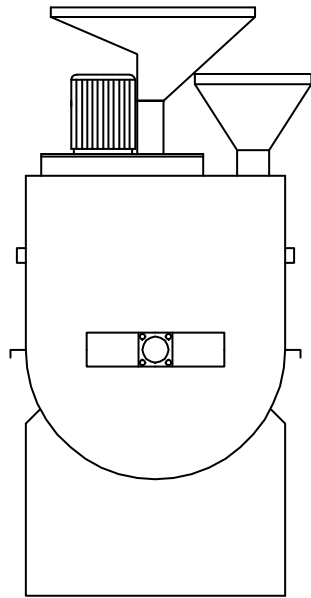

www.himmel.de

Pos.	Menge	Einheit	Benennung	Sachnummer / Norm-Kurzbezeichnung		Bemerkung
				Oberfläche	Maßstab 1:20	Position Menge
				Datum	Name	Horizontalmischer HOM 10
				Bearb. 14.09.04	Schumacher	
				Gepr.		
				Norm		
				HIMEL Maschinen GmbH & Co. KG Mittelhofen 11 72393 Burladingen 7 Telefon: 07126/92994-0 Telefax: 07126/9299-1		Blatt
						0002092
						Bl
Zust.	Änderung		Datum	Name	EDV Nr.	

8 7 6 5 4 3 2 1

F  
E  
D  
C  
B  
A

F  
E  
D  
C  
B  
A

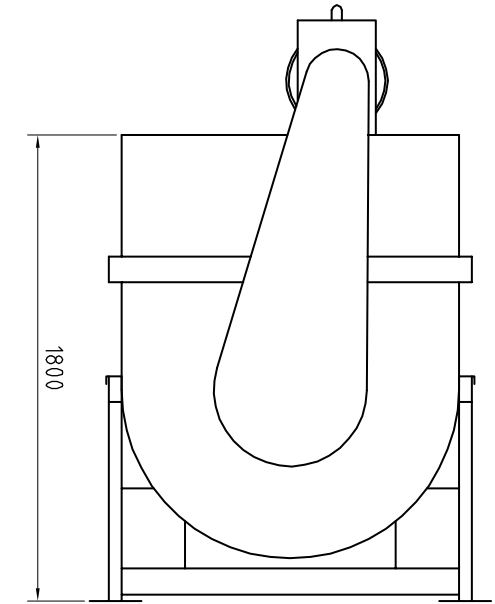
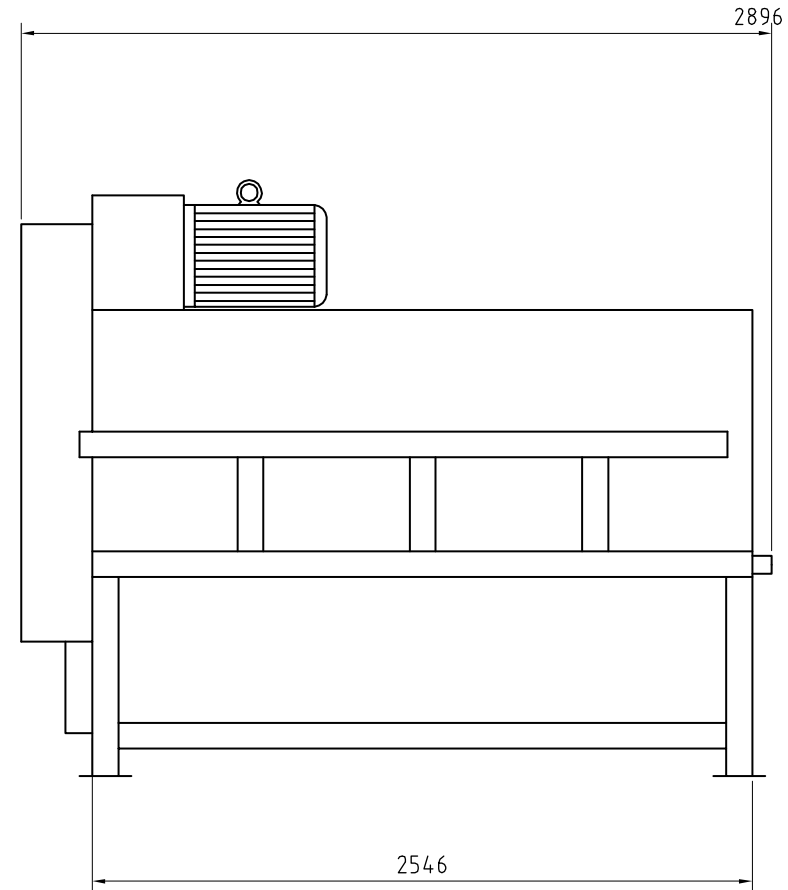
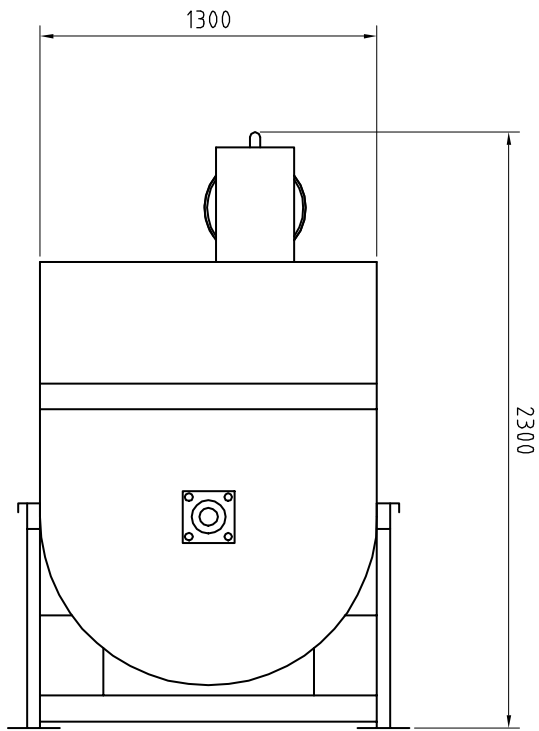

www.himmel.de

Pos.	Menge	Einheit	Benennung	Sachnummer / Norm-Kurzbezeichnung		Bemerkung
				Oberfläche	Maßstab 1:20	Position Menge
			Datum Name	Horizontalmischer HOM 20  0002278		
			Bearb. 14.09.04 Schumacher			
			Gepr.			
			Norm			
			HIMEL Maschinen GmbH & Co. KG Mittelhofen 11 72393 Burladingen 7 Telefon: 07126/92994-0 Telefax: 07126/9299-1		Blatt	
			EDV Nr.		Bl	
Zust.	Änderung	Datum	Name			

