

<input checked="" type="checkbox"/>	<input checked="" type="checkbox"/>	Rz100	.	.
<input checked="" type="checkbox"/>	<input checked="" type="checkbox"/>	Rz25	.	.
<input checked="" type="checkbox"/>	<input checked="" type="checkbox"/>	Rz6.3	.	.
<input checked="" type="checkbox"/>		Kanten entgratet	Paßmaß	Abmaß

Längenmaße								Maßstab 1:20			Gewicht in kg ca. .		Stück/pro Maschine 1	
-6	-30	-120	-400	-1000	-2000	-4000	-6000	Allgemeintoleranz DIN 2768 mittel			Werkstoff .			
+0,1	+0,2	+0,3	+0,5	+0,8	+1,2	+2	+3	2004	Datum	Name	Rohteil/Abmessungen .			
								Bearb.	18.02.	Schumacher	Benennung			
								Gepr.			HS75 5,5kW			
								Norm			Verwendungsbereich			
											Hochleistungsschrotmühle			
											Zeichnungsnummer		Blatt	
											0000113		1 (.)	
													A3	
Zust	Änderung	Datum	Name	Vertrauliche Unterlagen Schutz DIN 34 beansprucht				Baogr. .		Masch. .				

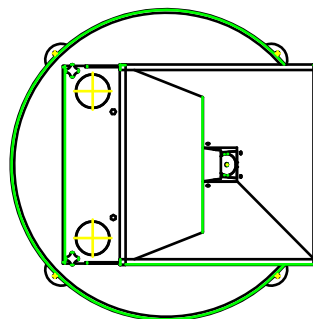

HVEL Maschinen  
GmbH & Co. KG  
Hilfshofen 11  
72393 Burladingen 7  
Telefon: 07126/929940  
Telefax: 07126/9299-1

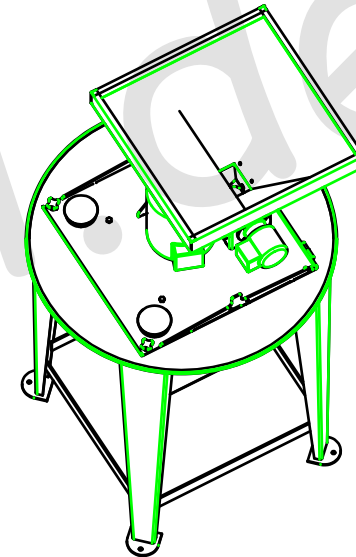
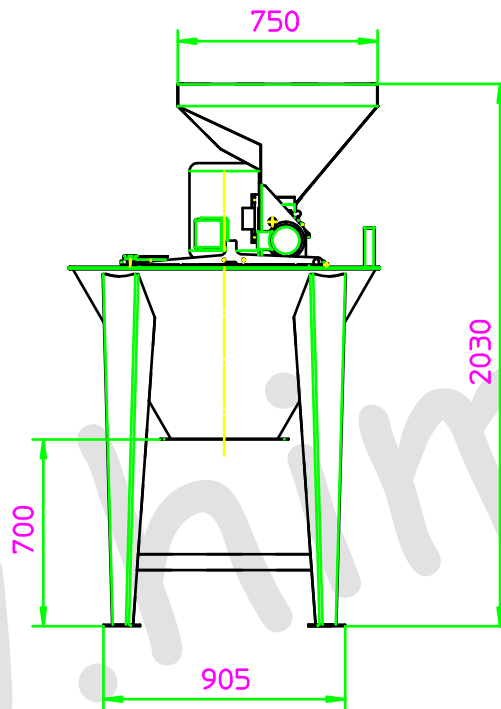
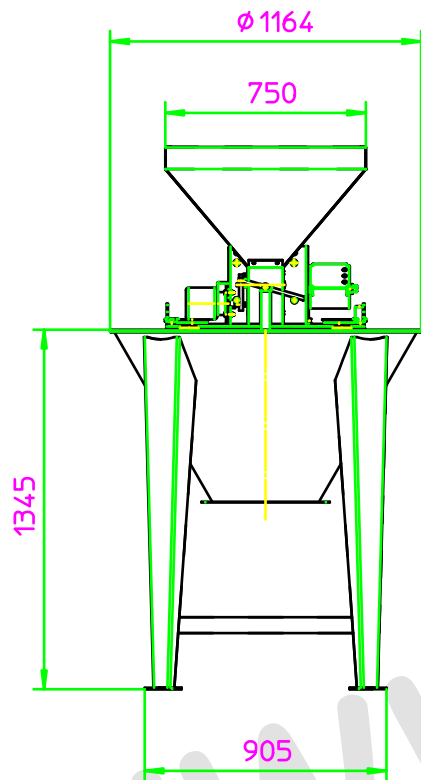

<input checked="" type="checkbox"/>	<input checked="" type="checkbox"/>	Rz100	.	.
<input checked="" type="checkbox"/>	<input checked="" type="checkbox"/>	Rz25	.	.
<input checked="" type="checkbox"/>	<input checked="" type="checkbox"/>	Rz0.3	.	.
<input checked="" type="checkbox"/>	<input checked="" type="checkbox"/>	Kanten entgratet	Paßmaß	Abmaß

Längenmaße								Maßstab 1:20			Gewicht in kg ca. .		Stück/pro Maschine 1		
-6	-30	-120	-400	-1000	-2000	-4000	-5000	Allgemeintoleranz DIN 2768 mittel			Werkstoff .				
+0,1	+0,2	+0,3	+0,5	+0,8	+1,2	+2	+3	2004	Datum	Name	Rohteil/Abmessungen .				
								Bearb.	18.02.	Schumacher	Benennung				
								Gepr.			HS100 7,5kW				
								Norm			Verwendungsbereich				
											Hochleistungsschrotmühle				
											Zeichnungsnummer		Blatt		
											0000114		1 (.)		
											A3				
								Vertrauliche Unterlagen			Baogr. .				
								Schutz DIN 34 beansprucht			Masch. .				
Zust	Änderung	Datum	Name												



HVEL Maschinen  
GmbH & Co. KG  
Hilfshofen 11  
72393 Burladingen 7  
Telefon: 07126/929940  
Telefax: 07126/9299-1

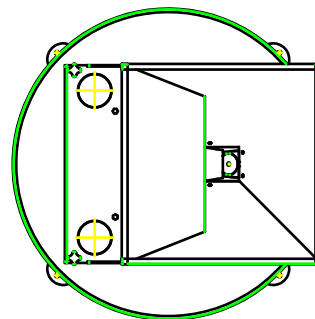
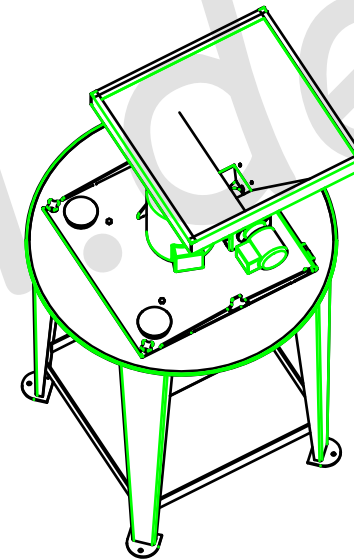
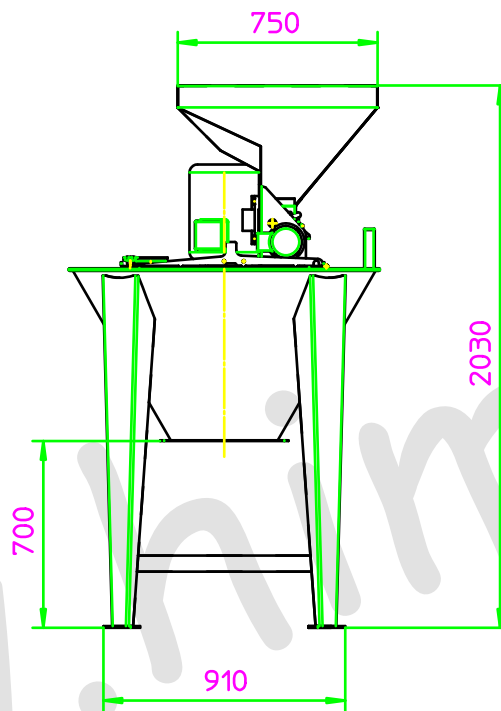
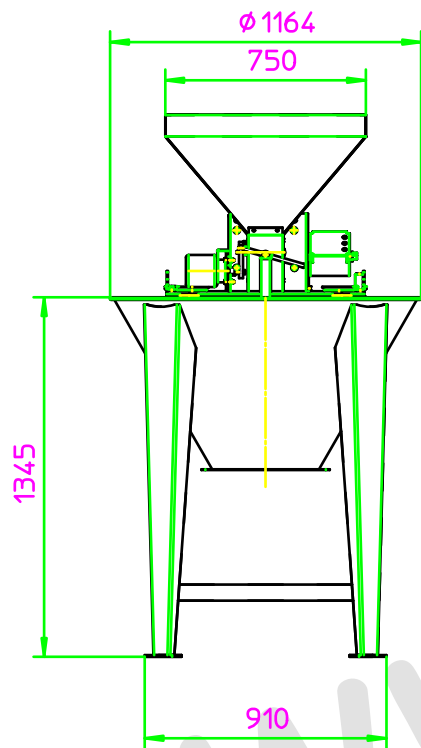

<input checked="" type="checkbox"/>	<input checked="" type="checkbox"/>	Rei00	.	.
<input checked="" type="checkbox"/>	<input checked="" type="checkbox"/>	Rei25	.	.
<input checked="" type="checkbox"/>	<input checked="" type="checkbox"/>	Rei35	.	.
<input checked="" type="checkbox"/>	<input checked="" type="checkbox"/>	Kanten entgratet	Paßmaß	Abmaß

Längenmaße								Maßstab 1:20			Gewicht in kg ca. .		Stück/pro Maschine 1	
-6	-30	-120	-400	-1000	-2000	-4000	-6000	Allgemeintoleranz DIN 2768 mittel			Werkstoff .			
+0,1	+0,2	+0,3	+0,5	+0,8	+1,2	+2	+3	2004	Datum	Name	Rahtell/Abmessungen .			
								Bearb.	18.02.	Schumacher	Benennung			
								Gepr.			HS150 11kW			
								Norm			Verwendungsbereich			
											Hochleistungsschrotmühle			
								<small>HVEL Maschinen GmbH &amp; Co. KG Hilfshofen 11 72393 Burladingen 7 Telefon: 07126/929940 Telefax: 07126/9299-1</small> 			Zeichnungsnummer		Blatt	
								Vertrauliche Unterlagen			0000115		1 (.)	
								Schutz DIN 34 beansprucht			A3			
Zust	Änderung	Datum	Name	Baugr. .				Masch. .						

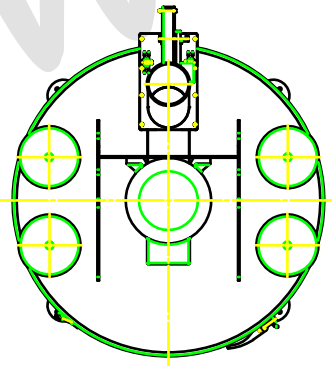
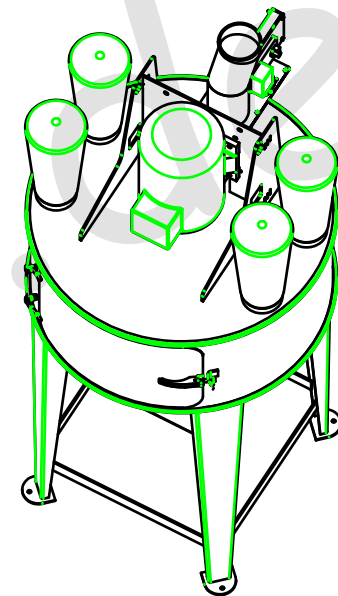
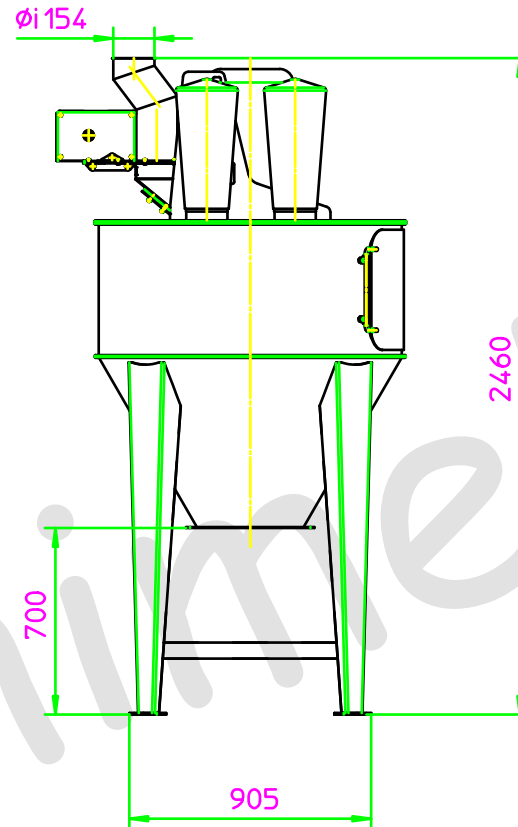
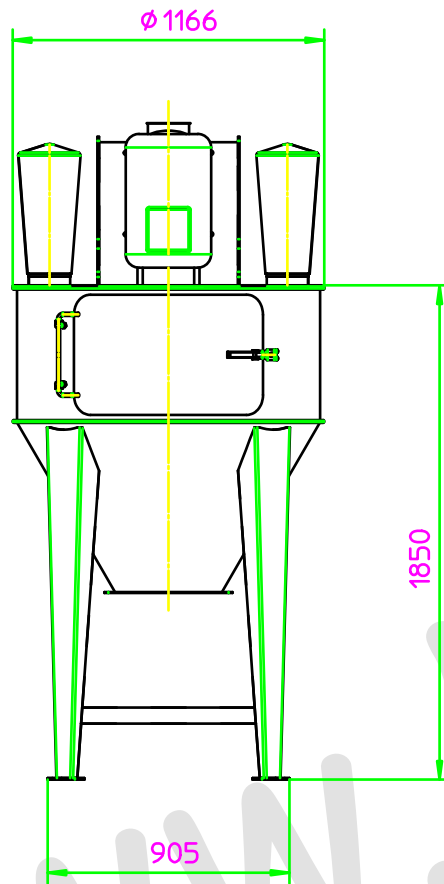

✓	✓	Rz100	.	.
✓	✓	Rz25	.	.
✓	✓	Rz3	.	.
Kanten entgratet	Paßmaß	Abmaß	.	.

Längenmaße				Maßstab 1:20				Gewicht in kg ca. .		Stk/pro Maschine 1
-6	-30	-120	-600	-1000	-2000	-4000	-6000	Allgemeintoleranz DIN 2768 mittel		
+0,1	+0,2	+0,3	+0,5	+0,8	+1,2	+2	+3	2004 Datum Name		Werkstoff .
Bearb. 15.09. Schumacher								Rohteil/Abmessungen .		
Gepr.								Benennung		
Norm								HS250 18,5kW		
HVEL Maschinen GmbH & Co. KG Hilfshofen 11 72393 Burladingen 7 Telefon: 07126/92940 Telefax: 07126/9299-1								Verwendungsbereich Hochleistungsschrotmühle		
Vertrauliche Unterlagen Schutz DIN 34 beansprucht								Zeichnungsnummer		Blatt 1 (.) A3
Zust	Änderung	Datum	Name	Baugr. .		Masch. .				

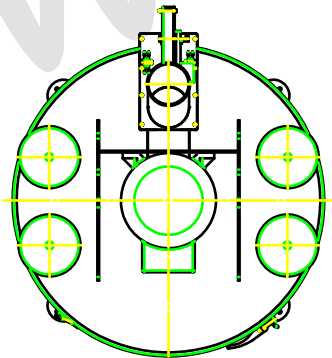
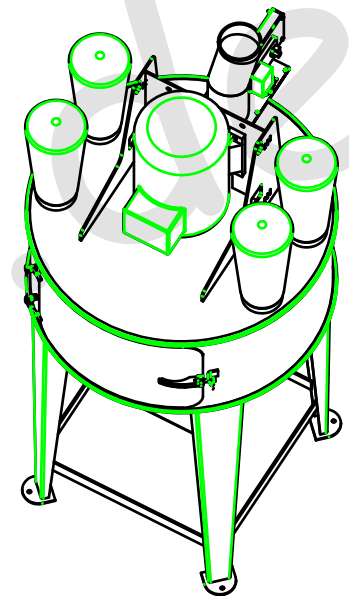
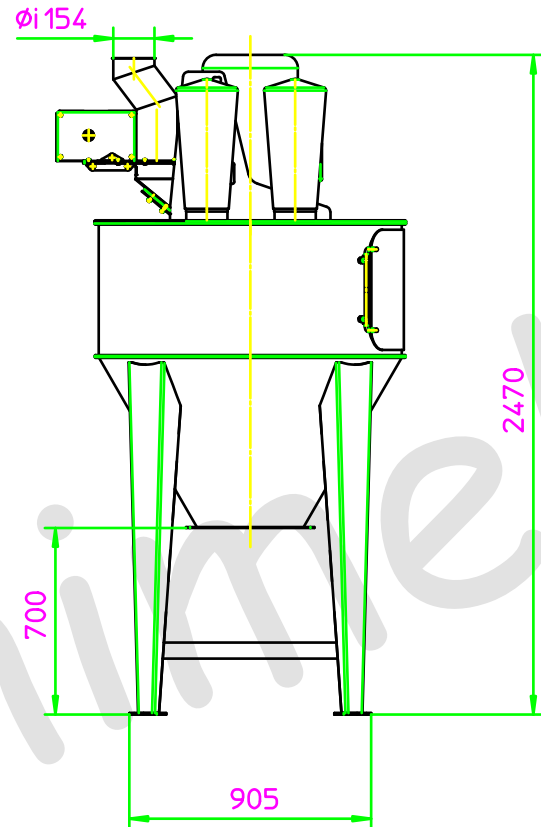
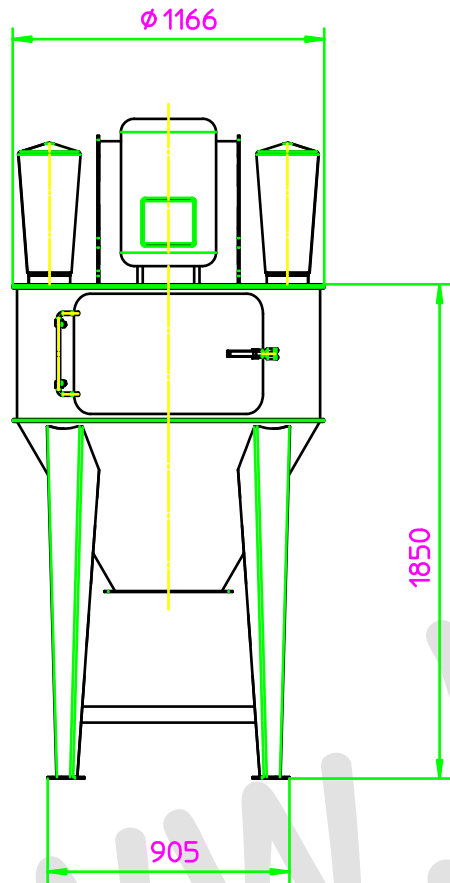

✓	✓	Rz100	.	.
✓	✓	Rz25	.	.
✓	✓	Rz6.3	.	.
Kanten entgratet	Paßmaß	Abmaß	.	.

Längenmaße				Maßstab 1:20				Gewicht in kg ca. .		Stück/pro Maschine 1	
-6	-30	-120	-400	-1000	-2000	-4000	-5000	Allgemeintoleranz DIN 2768 mittel			
+0,1	+0,2	+0,3	+0,5	+0,8	+1,2	+2	+3	2004 Datum Name			
Bearb. 15.09. Schumacher								Rohteil/Abmessungen .			
Gepr.								Benennung			
Norm								HS300 22kW			
HVEL Maschinen GmbH & Co. KG Hilfshofen 11 72393 Burladingen 7 Telefon: 07126/92940 Telefax: 07126/9299-1								Verwendungsbereich Hochleistungsschrotmühle			
Vertrauliche Unterlagen Schutz DIN 34 beansprucht								Zeichnungsnummer 0000109		Blatt 1 (.) A3	
Zust	Änderung	Datum	Name	Baugr. .				Masch. .			

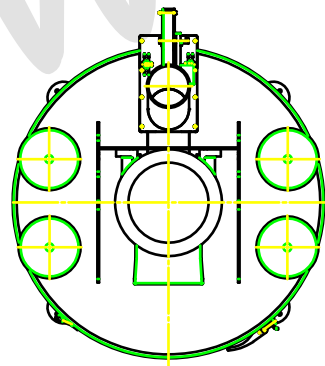
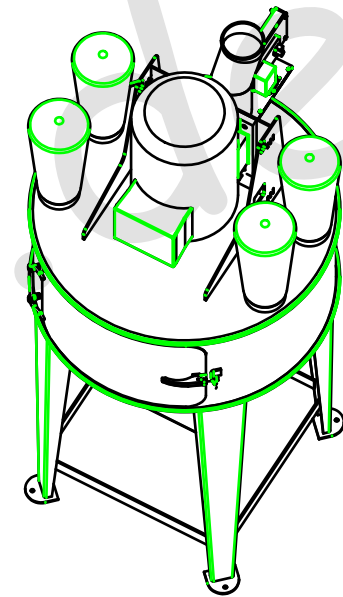
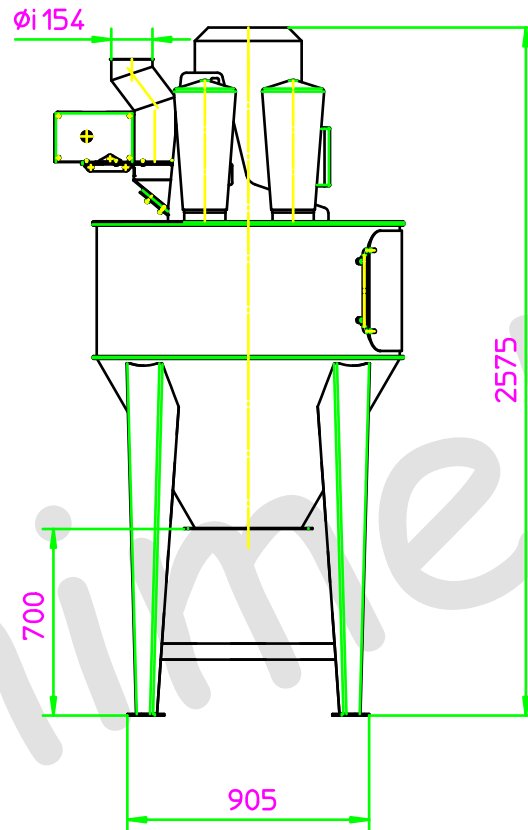
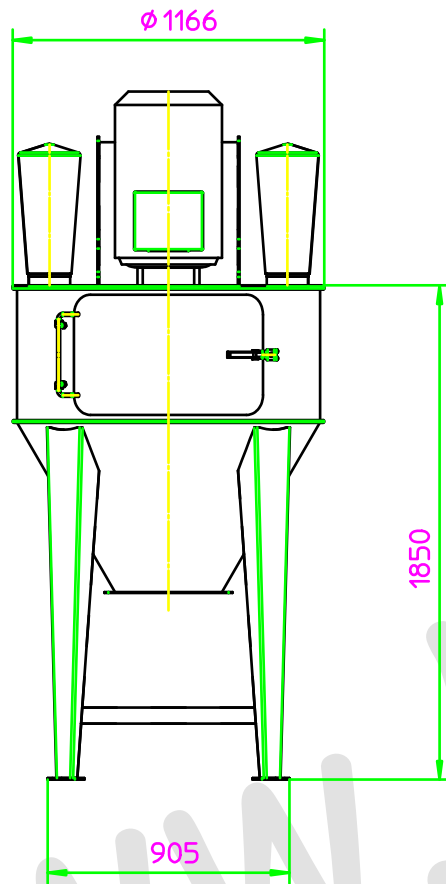

<input checked="" type="checkbox"/>	<input checked="" type="checkbox"/>	Reizo	.	.
<input checked="" type="checkbox"/>	<input checked="" type="checkbox"/>	Rezo	.	.
<input checked="" type="checkbox"/>	<input checked="" type="checkbox"/>	Rezo	.	.
<input checked="" type="checkbox"/>	<input checked="" type="checkbox"/>	Kanten entgratet	Paßmaß	Abmaß

Längenmaße								Maßstab 1:20			Gewicht in kg ca. .		Stück/pro Maschine 1	
-6	-30	-120	-400	-1000	-2000	-4000	-5000	Allgemeintoleranz DIN 2768 mittel			Werkstoff .			
+0,1	+0,2	+0,3	+0,5	+0,8	+1,2	+2	+3	2004	Datum	Name	Rohteil/Abmessungen .			
								Bearb. 15.09.		Schumacher		Benennung		
								Gepr.				HS400 30kW		
								Norm				Verwendungsbereich		
												Hochleistungsschrotmühle		
												Zeichnungsnummer		
												0000110		
												Blatt		
												1 (.)		
												A3		
												Vertrauliche Unterlagen		
												Schutz DIN 34 beansprucht		
												Baogr. .		
												Masch. .		
Zust	Änderung			Datum	Name			Vertrauliche Unterlagen			Baogr. .			
												Masch. .		



HWE Maschinen  
GmbH & Co. KG  
Hilfshofen 11  
72393 Burladingen 7  
Telefon: 07126/92940  
Telefax: 07126/9299-1

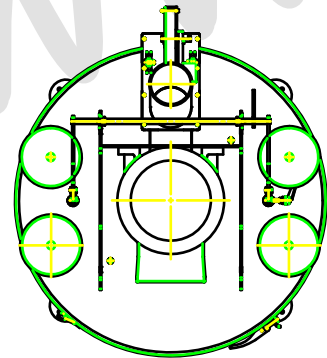
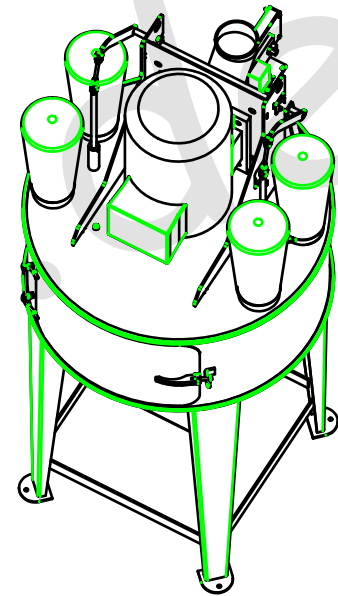
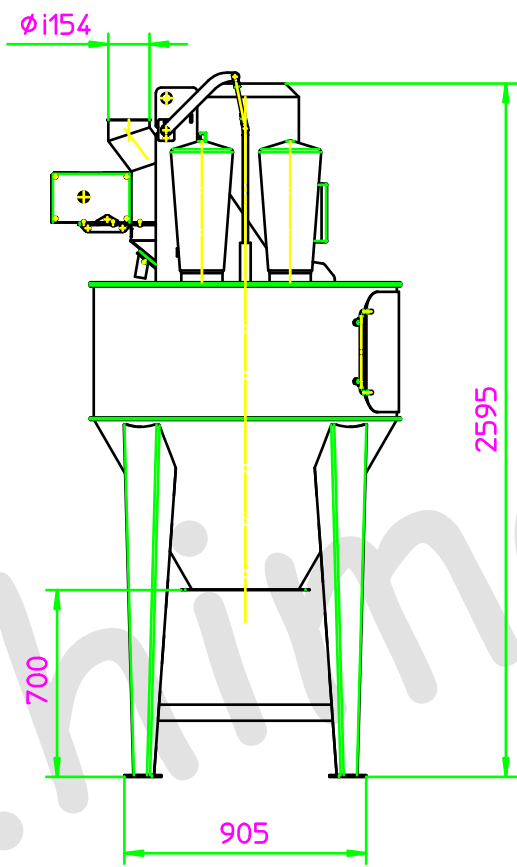
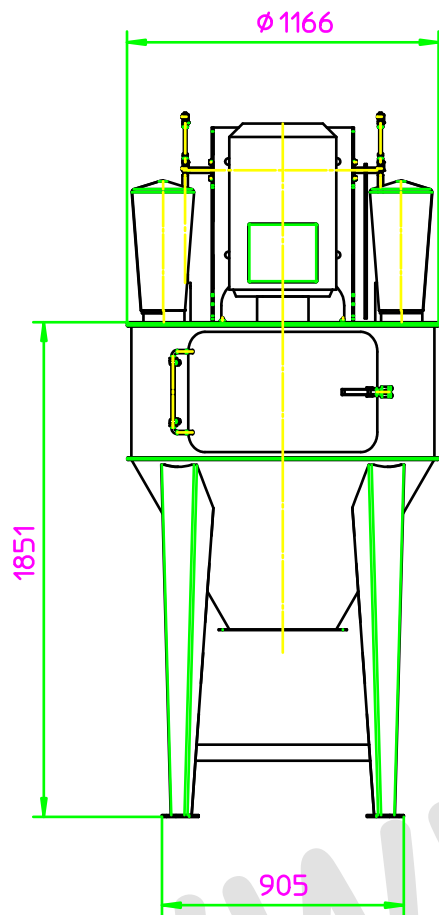

✓	✓	Rz100	.	.
✓	✓	Rz25	.	.
✓	✓	Rz0,3	.	.
Kanten entgratet		Paßmaß	Abmaß	

Längenmaße							Maßstab 1:20			Gewicht in kg ca.		Stück/pro Maschine	
-6	-30	-120	-400	-1000	-2000	-4000	-5000	Allgemeintoleranz DIN 2768 mittel			Werkstoff .		
+0,1	+0,2	+0,3	+0,5	+0,8	+1,2	+2	+3	2004	Datum	Name	Rohteil/Abmessungen .		
Bearb. 12.03. Schumacher									Benennung				
Gepr.									HS500 37kW				
Norm									Verwendungsbereich				
HVEL Maschinen GmbH & Co. KG Hilfshofen 11 72393 Burladingen 7 Telefon: 07126/929940 Telefax: 07126/9299-1									Hochleistungsschrotmühle				
Vertrauliche Unterlagen									Zeichnungsnummer		Blatt		
Schutz DIN 34 beansprucht									0000111		1		
Zust	Änderung	Datum	Name	Baugr. .				Masch. .					

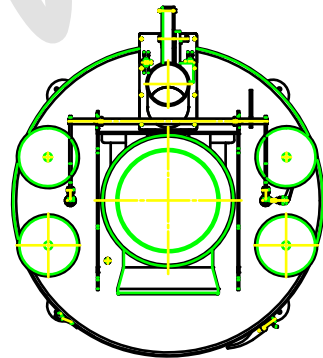
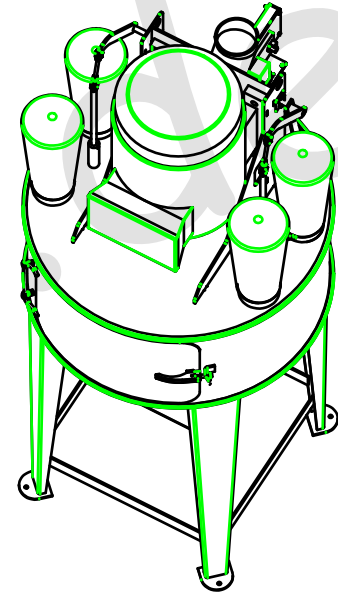
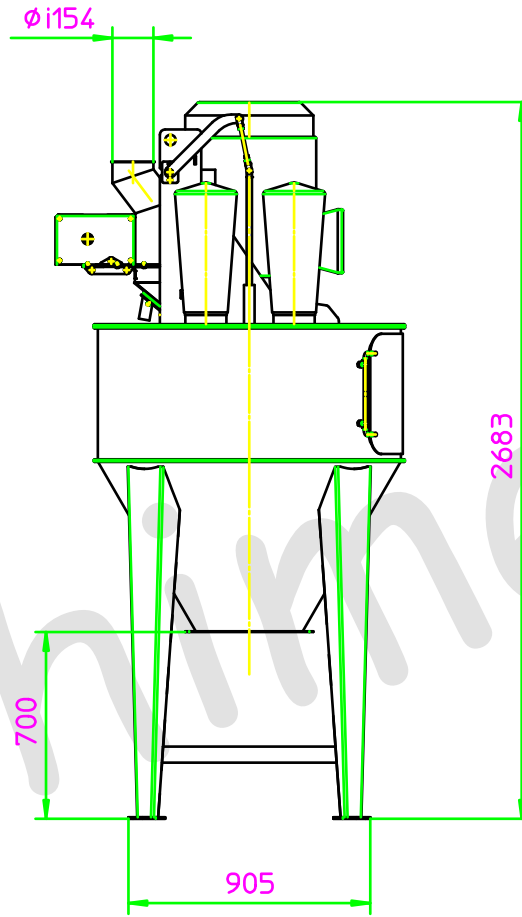
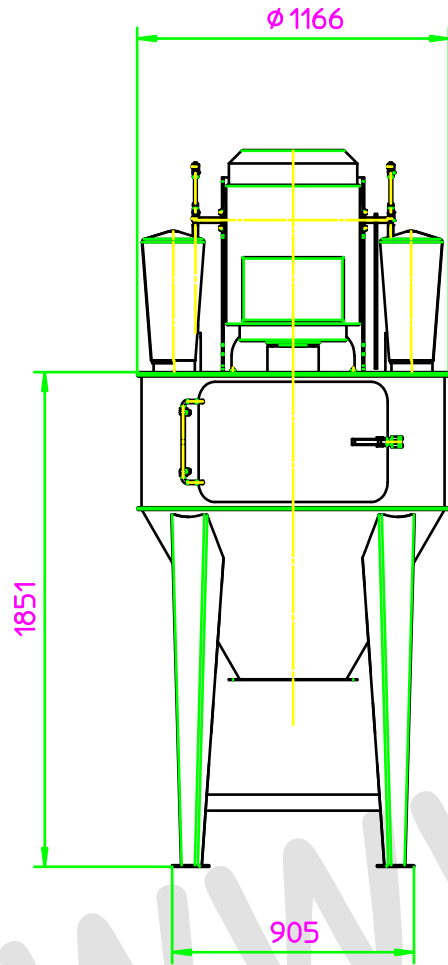

✓	✓	Rz100	.	.
✓	✓	Rz25	.	.
✓	✓	Rz6.3	.	.
✓	✓	Kanten entgratet	Paßmaß	Abmaß

Längenmaße				Maßstab 1:20				Gewicht in kg ca. .		Stück/pro Maschine 1		
-6	-30	-120	-400	-1000	-2000	-4000	-5000	Allgemeintoleranz DIN 2768 mittel		Werkstoff .		
+0,1	+0,2	+0,3	+0,5	+0,8	+1,2	+2	+3	2004	Datum	Name	Rohteil/Abmessungen .	
								Bearb.	12.03.	C. Peric	Benennung	
								Gepr.			HS750 55kW	
								Nom.			Verwendungsbereich	
											Hochleistungsschrotmühle	
											Zeichnungsnummer	Blatt
											0001939	1
												A3
Zust	Änderung	Datum	Name	Vertrauliche Unterlagen				Baogr. .		Masch. .		
				Schutz DIN 34 beansprucht								



HVEL Maschinen  
GmbH & Co. KG  
Hilfshofen 11  
72393 Burladingen 7  
Telefon: 07126/92940  
Telefax: 07126/9299-1