

- 2900685
- 3500353
- 3500034
- 3500037
- 2200655
- 2900723
- 1100501
- 3000355
- 3000358
- 3000359
- 3000254
- 1100599
- 3000148
- 3000133
- 2200654
- 2900722
- 3500112
- 3500311
- 3500112
- 2902710
- 3000063
- 3000148
- 2900684
- 1100243
- 1100242
- 1100214
- 1100252
- 3000254
- 5040021
- 1100257
- 3500112
- 3500001

www.himel.de

✓	✓	Rz100	.	.
✓	✓	Rz25	.	.
✓	✓	Rz6.3	.	.
Kanten entgratet		Paßmaß	Abmaß	

Längenmaße								Maßstab 1:15	Gewicht in kg ca. .	Stck.pro Maschine 1
-6	-30	-120	-400	-1000	-2000	-4000	-8000	Allgemeintoleranz DIN 2768 mittel	Werkstoff .	
±0.1	+0.2	+0.3	+0.5	+0.8	+1.2	+2	+3			
Bearb.	Datum		Name		Rauteil/Abmessungen .					
Gepr.	06.05.03		Schumacher		Benennung					
Norm					Ersatzteilliste					
HIMEL Maschinen GmbH & Co. KG Mittelhafen 11 72393 Burladingen 7 Telefon: 07126/929940 Telefax: 07126/9299-1								Verwendungsbereich		
								Futtermischer FM60		
Vertrauliche Unterlagen								Zeichnungsnummer		
Schutz DIN 34 beansprucht								0000001		
Zust	Änderung	Datum	Name		Baugr. .		Masch. .		Blatt 1	
								A3		

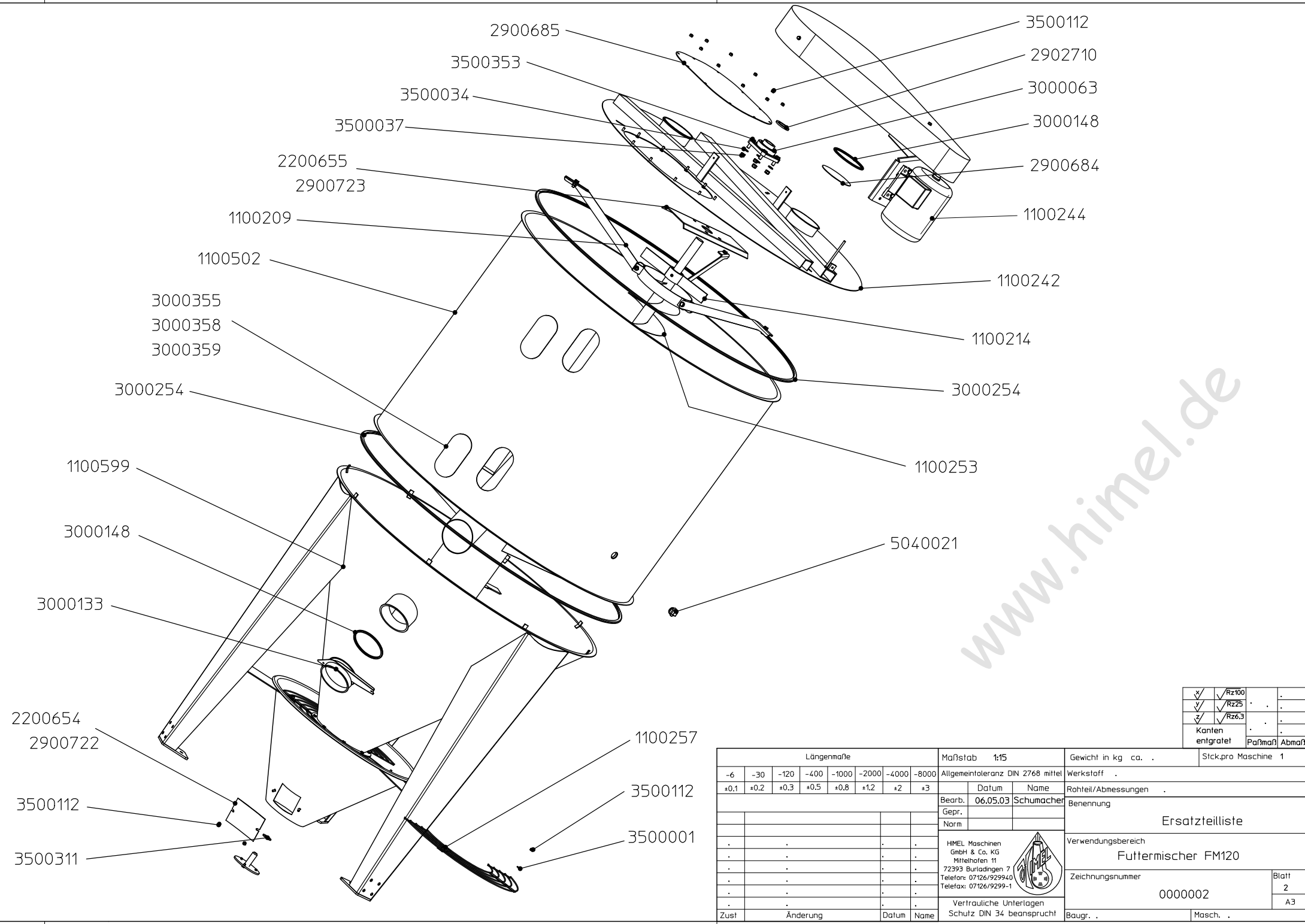

www.himel.de

✓	✓	Rz100	.	.
✓	✓	Rz25	.	.
✓	✓	Rz6.3	.	.
✓	✓	Kanten entgratet	.	.
		Paßmaß	Abmaß	

Längenmaße								Maßstab 1:15	Gewicht in kg ca. .	Stck.pro Maschine 1
-6	-30	-120	-400	-1000	-2000	-4000	-8000	Allgemeintoleranz DIN 2768 mittel	Werkstoff .	
+0.1	+0.2	+0.3	+0.5	+0.8	+1.2	+2	+3			
Bearb.	Datum		Name		Rauteil/Abmessungen .					
Gepr.	06.05.03		Schumacher		Benennung					
Norm	Ersatzteilliste									
Verwendungsbereich								Blatt		
Futtermischer FM120								2		
Zeichnungsnummer								A3		
0000002										
Vertrauliche Unterlagen								Baogr. .		
Schutz DIN 34 beansprucht								Masch. .		
Zust	Änderung	Datum	Name							



www.himel.de

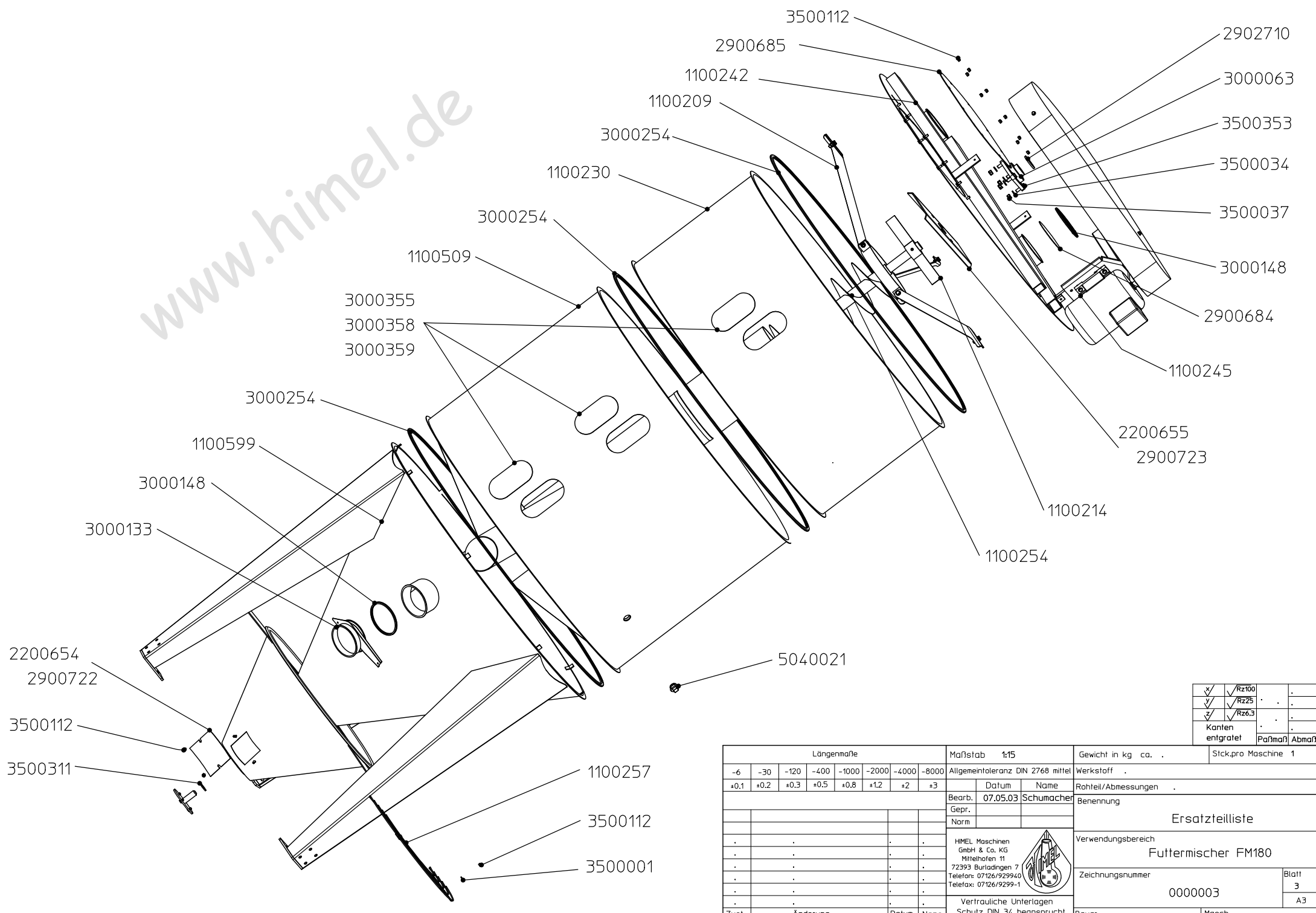

✓	✓	Rz100	.	.
✓	✓	Rz25	.	.
✓	✓	Rz6.3	.	.
✓	✓	Kanten entgratet	Paßmaß	Abmaß

Längenmaße								Maßstab 1:15	Gewicht in kg ca. .	Stck.pro Maschine 1
-6	-30	-120	-400	-1000	-2000	-4000	-8000	Allgemeintoleranz DIN 2768 mittel	Werkstoff .	
+0.1	+0.2	+0.3	+0.5	+0.8	+1.2	+2	+3	Bearb. 07.05.03	Datum Name	
								Gepr.	Teil/Abmessungen .	
								Norm	Benennung	
								Ersatzteilliste		
								Verwendungsbereich		
								Futtermischer FM180		
								Zeichnungsnummer		
								0000003		
								Blatt		
								3		
								A3		
								Vertrauliche Unterlagen		
								Schutz DIN 34 beansprucht		
Zust	Änderung			Datum	Name		Baogr. .		Masch. .	



www.himel.de

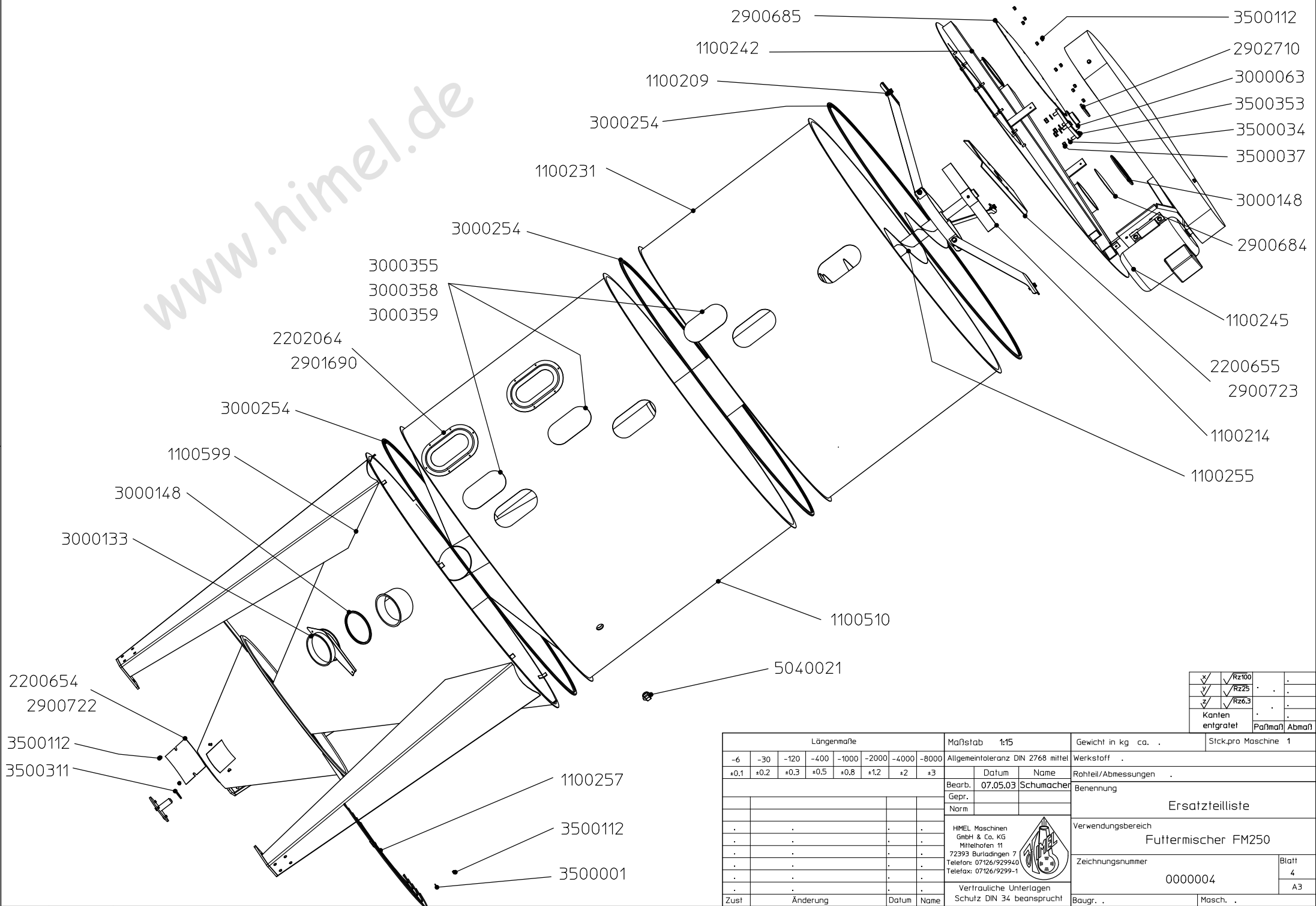

✓	✓	Rz100	.	.
✓	✓	Rz25	.	.
✓	✓	Rz6.3	.	.
Kanten entgratet		Paßmaß	Abmaß	

Längenmaße								Maßstab 1:15	Gewicht in kg ca. .	Stck.pro Maschine 1
-6	-30	-120	-400	-1000	-2000	-4000	-8000	Allgemeintoleranz DIN 2768 mittel	Werkstoff .	
+0.1	+0.2	+0.3	+0.5	+0.8	+1.2	+2	+3	Bearb. Datum Name	Rahteil/Abmessungen .	
								Gepr. 07.05.03 Schumacher	Benennung	
								Norm	Ersatzteilliste	
								HIMEL Maschinen GmbH & Co. KG Mittelhafen 11 72393 Burladingen 7 Telefon: 07126/929940 Telefax: 07126/9299-1	Verwendungsbereich	
									Futtermischer FM250	
								Vertrauliche Unterlagen Schutz DIN 34 beansprucht	Zeichnungsnummer	
Zust	Änderung	Datum	Name						0000004	
									Baugr. .	
									Masch. .	

www.himel.de

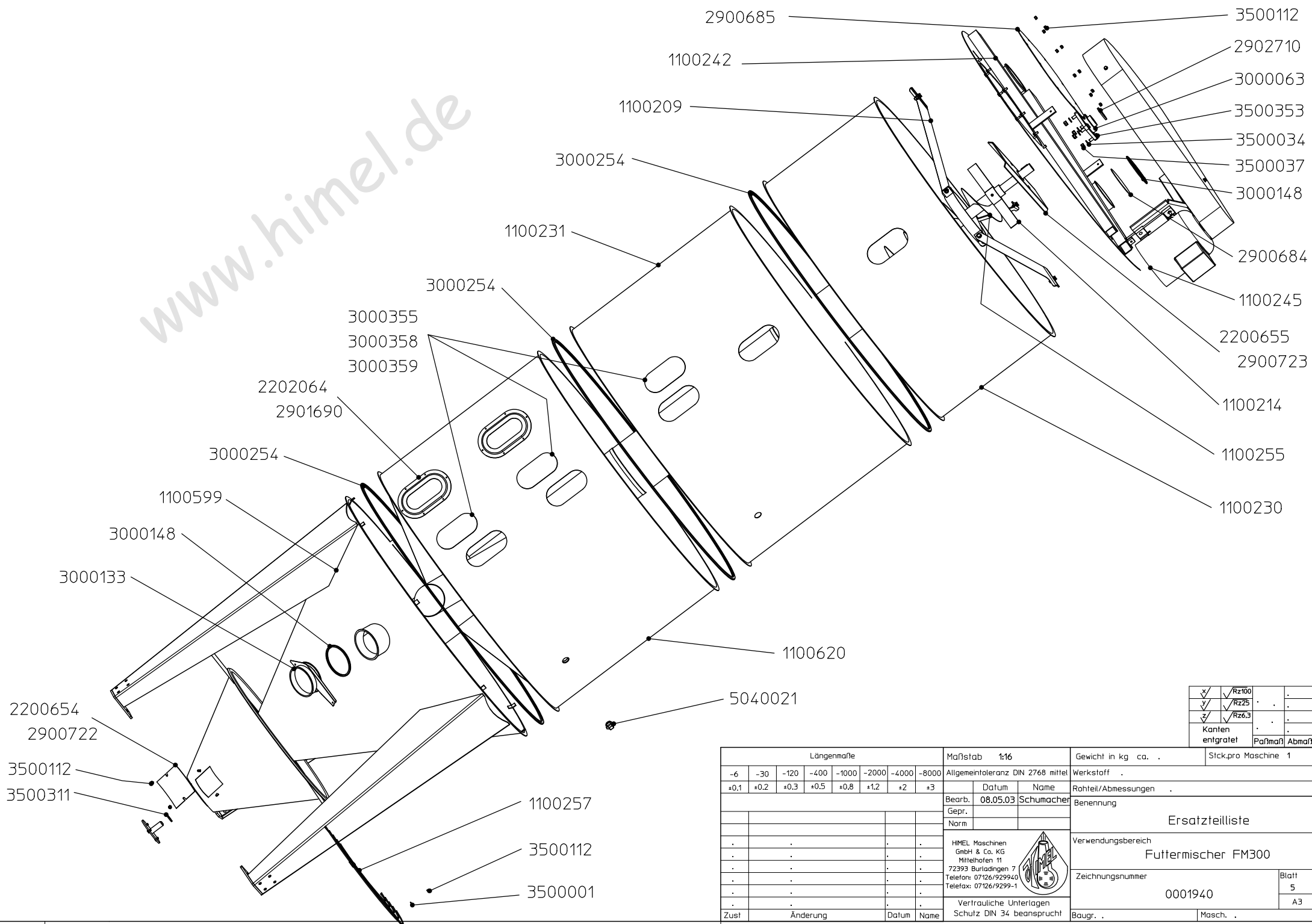

✓	✓	Rz100	.	.
✓	✓	Rz25	.	.
✓	✓	Rz6.3	.	.
✓	✓	Kanten entgratet	Paßmaß	Abmaß

Längenmaße								Maßstab 1:16	Gewicht in kg ca. .	Stck.pro Maschine 1
-6	-30	-120	-400	-1000	-2000	-4000	-8000	Allgemeintoleranz DIN 2768 mittel	Werkstoff .	
+0.1	+0.2	+0.3	+0.5	+0.8	+1.2	+2	+3	Bearb. 08.05.03	Datum Name	
								Gepr.	Schumacher	
								Norm	Benennung	
									Ersatzteilliste	
									Verwendungsbereich	
									Futtermischer FM300	
									Zeichnungsnummer	
									0001940	
									Blatt	
									5	
									A3	
Zust	Änderung	Datum	Name	Vertrauliche Unterlagen				Schutz DIN 34 beansprucht	Baugr. .	Masch. .



www.himel.de

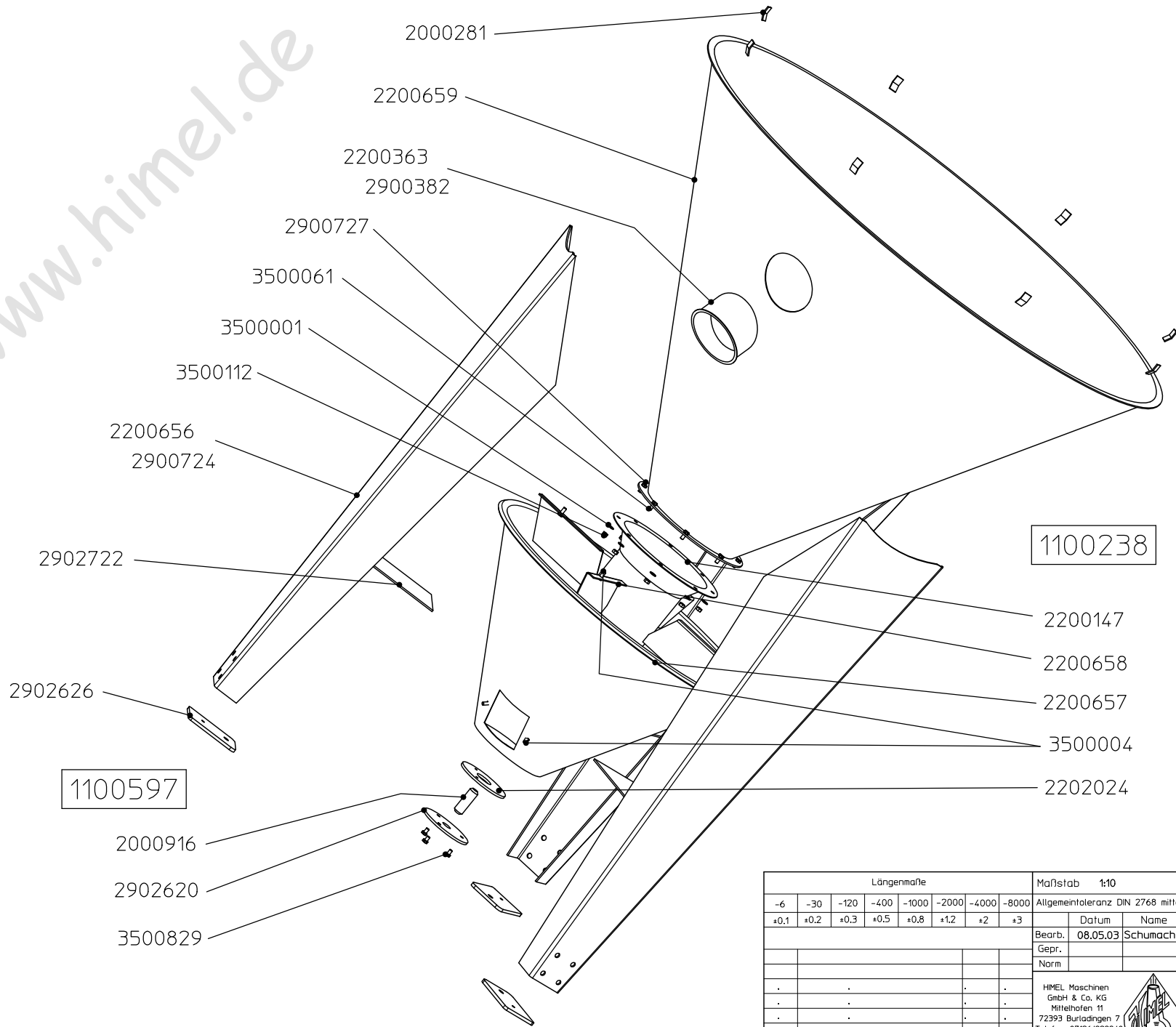

1100597

1100238

2902626

2902722

2200656

2900724

3500112

3500001

3500061

2900727

2200363

2900382

2200659

2000281

2200147

2200658

2200657

3500004

2202024

2000916

2902620

3500829

✓	✓	Rz100	.	.
✓	✓	Rz25	.	.
✓	✓	Rz6.3	.	.
✓	✓	Kanten entgratet	.	.
		Paßmaß	Abmaß	

Längenmaße								Maßstab 1:10		Gewicht in kg ca. .		Stck.pro Maschine 1			
-6	-30	-120	-400	-1000	-2000	-4000	-8000	Allgemeintoleranz DIN 2768 mittel		Werkstoff .					
+0.1	+0.2	+0.3	+0.5	+0.8	+1.2	+2	+3	Bearb.	Datum	Name	Rahteil/Abmessungen .				
								Gepr.	08.05.03	Schumacher	Benennung				
								Norm			Ersatzteilliste				
.	.	.	.	.	.	.	.	HIMEL Maschinen GmbH & Co. KG							
.	.	.	.	.	.	.	.	Mittelhafen 11							
.	.	.	.	.	.	.	.	72393 Burladingen 7							
.	.	.	.	.	.	.	.	Telefon: 07126/929940 Telefax: 07126/9299-1							
Zust		Änderung		Datum		Name		Vertrauliche Unterlagen		Baogr. .		Masch. .			
										Schutz DIN 34 beansprucht		Verwendungsbereich		Blatt	
												Unterteil FM60-300		6	
												Zeichnungsnummer		A3	
												1100599			

www.himel.de

1100248

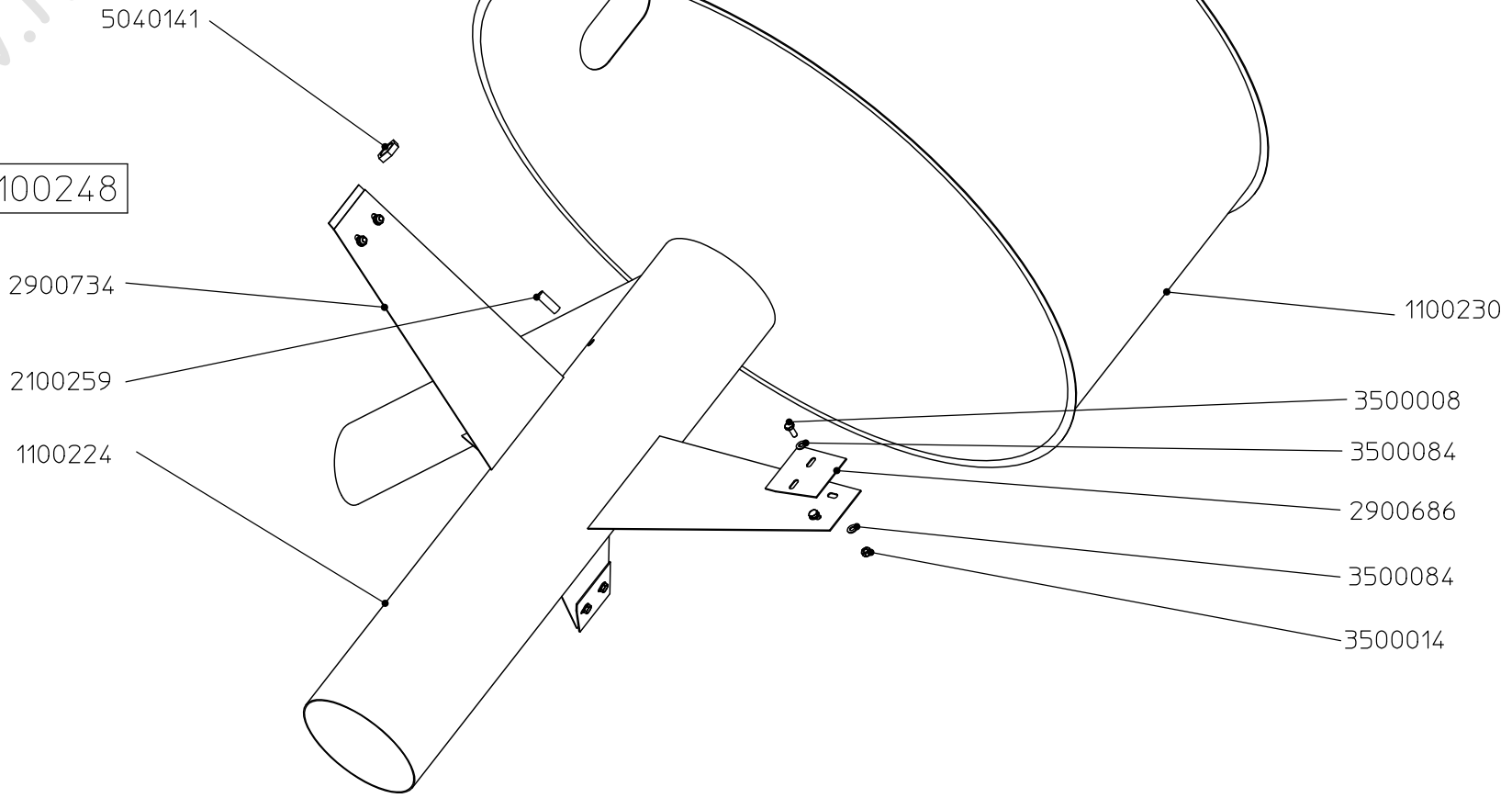

✓	✓	Rz100	.	.
✓	✓	Rz25	.	.
✓	✓	Rz6.3	.	.
Kanten entgratet		Paßmaß	Abmaß	

Längenmaße								Maßstab 1:10			Gewicht in kg ca. .		Stck.pro Maschine 1				
-6	-30	-120	-400	-1000	-2000	-4000	-8000	Allgemeintoleranz DIN 2768 mittel			Werkstoff .						
+0.1	+0.2	+0.3	+0.5	+0.8	+1.2	+2	+3	Datum		Name		Rauteil/Abmessungen .					
								Bearb. 08.05.03		Schumacher		Benennung					
								Gepr.				Ersatzteilliste					
								Norm									
								HIMEL Maschinen GmbH & Co. KG Mittelhafen 11 72393 Burladingen 7 Telefon: 07126/929940 Telefax: 07126/9299-1				Verwendungsbereich					
												Aufsatz mit 1 Fenster 695mm					
												Zeichnungsnummer		1100501		Blatt	
																8	
																A3	
Zust		Änderung		Datum		Name		Vertrauliche Unterlagen			Schutz DIN 34 beansprucht						
								Baugr. .		Masch. FM60							



www.himel.de

1100249

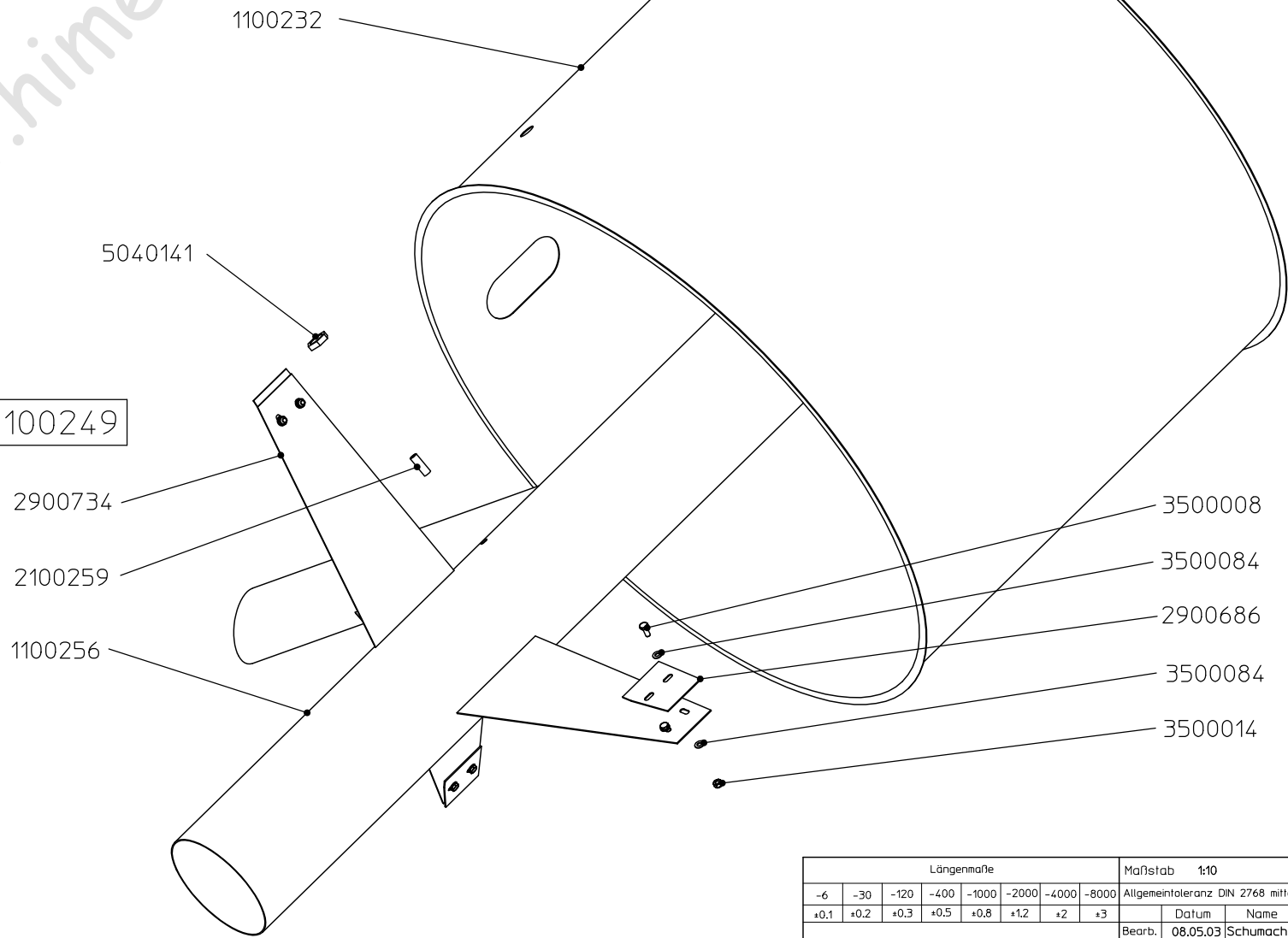

✓	✓	Rz100	.	.
✓	✓	Rz25	.	.
✓	✓	Rz6.3	.	.
✓	✓	Kanten entgratet	Paßmaß	Abmaß

Längenmaße								Maßstab 1:10		Gewicht in kg ca. .		Stck.pro Maschine 1	
-6	-30	-120	-400	-1000	-2000	-4000	-8000	Allgemeintoleranz DIN 2768 mittel		Werkstoff .			
±0.1	±0.2	±0.3	±0.5	±0.8	±1.2	±2	±3	Bearb.	Datum	Name	Rauteil/Abmessungen .		
								Gepr.		Benennung			
								Norm		Ersatzteilliste			
								HIMEL Maschinen GmbH & Co. KG Mittelhafen 11 72393 Burladingen 7 Telefon: 07126/929940 Telefax: 07126/9299-1		Verwendungsbereich Aufsatz mit 2 Fenster 1195mm			
								Vertrauliche Unterlagen Schutz DIN 34 beansprucht		Zeichnungsnummer 1100502		Blatt 8 A3	
Zust	Änderung		Datum		Name		Baugr. .		Masch. FM120				





www.himel.de

1100250

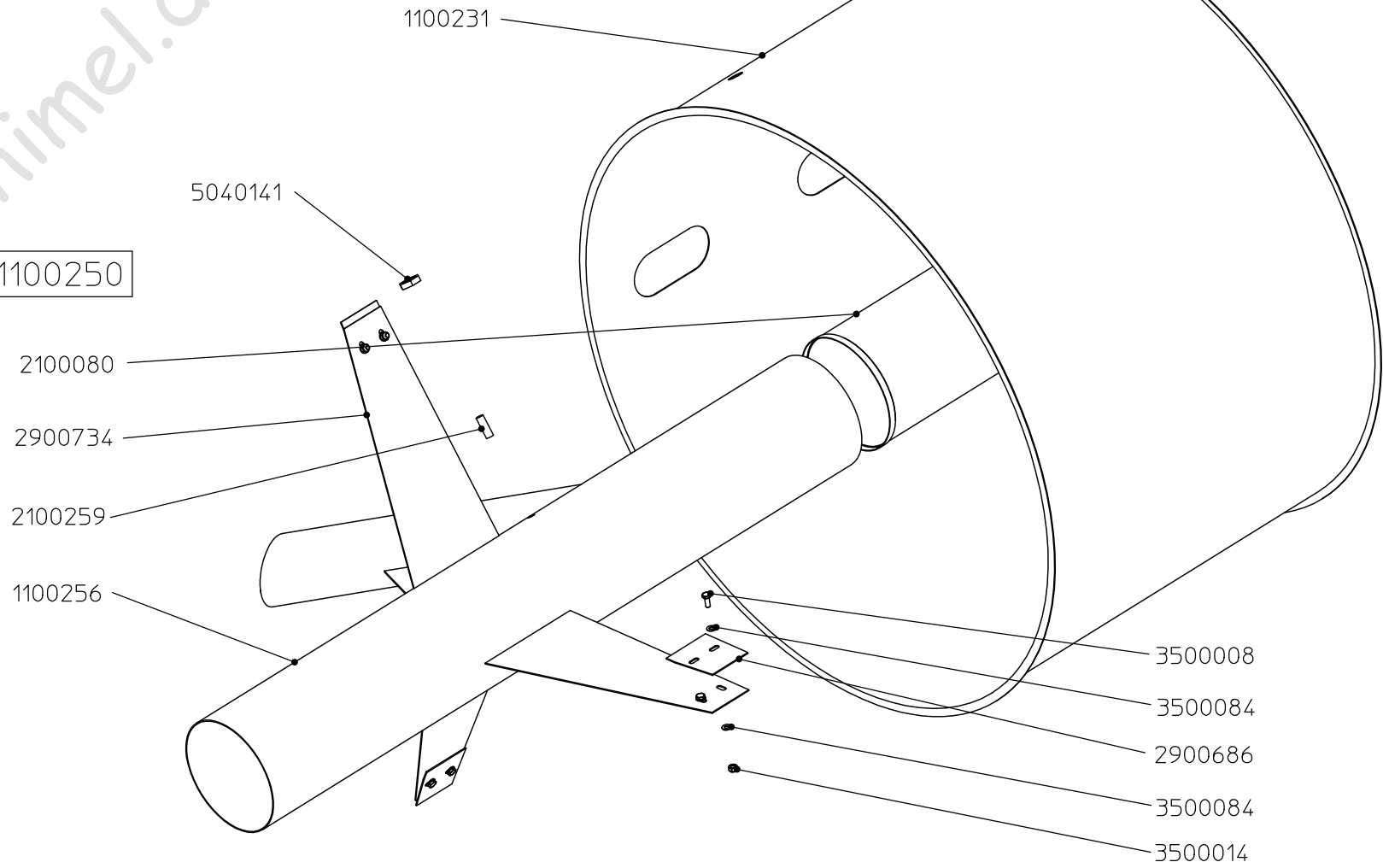

✓	✓	Rz100	.	.
✓	✓	Rz25	.	.
✓	✓	Rz6.3	.	.
✓	✓	Kanten entgratet	Paßmaß	Abmaß

Längenmaße								Maßstab 1:10		Gewicht in kg ca. .		Stck.pro Maschine 1			
-6	-30	-120	-400	-1000	-2000	-4000	-8000	Allgemeintoleranz DIN 2768 mittel		Werkstoff .					
+0.1	+0.2	+0.3	+0.5	+0.8	+1.2	+2	+3			Rauteil/Abmessungen .					
								Bearb. 08.05.03		Name Schumacher		Benennung			
								Gepr.				Ersatzteilliste			
								Norm				Verwendungsbereich			
								HIMEL Maschinen GmbH & Co. KG				Aufsatz mit 2 Fenster 1000mm			
								Mittelhafen 11				Zeichnungsnummer		Blatt	
								72393 Burladingen 7				1100509		9	
								Telefon: 07126/929940						A3	
								Telefax: 07126/9299-1		Vertrauliche Unterlagen		Baogr. .			
Zust								Änderung		Datum		Name		Masch. FM180	

www.himel.de

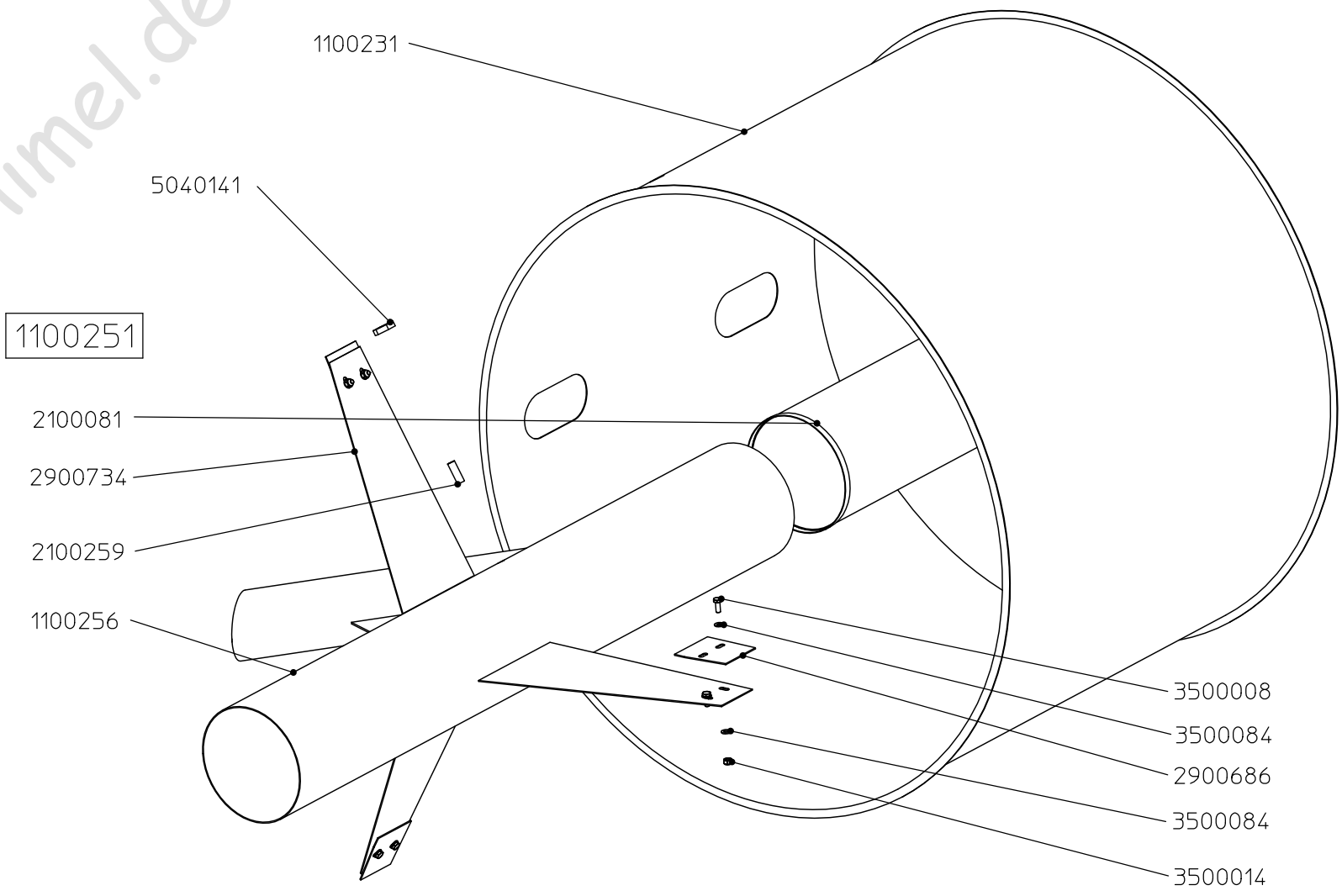

✓	✓	Rz100	.	.
✓	✓	Rz25	.	.
✓	✓	Rz6.3	.	.
✓	✓	Kanten entgratet	Paßmaß	Abmaß

Längenmaße								Maßstab 1:10			Gewicht in kg ca. .		Stck.pro Maschine 1		
-6	-30	-120	-400	-1000	-2000	-4000	-8000	Allgemeintoleranz DIN 2768 mittel			Werkstoff .				
+0.1	+0.2	+0.3	+0.5	+0.8	+1.2	+2	+3	Bearb. 08.05.03		Datum Name		Rauteil/Abmessungen .			
								Gepr.		Benennung		Ersatzteilliste			
								Norm							
								HIMEL Maschinen GmbH & Co. KG		Verwendungsbereich		Aufsatz mit 2 Fenster 1195mm			
								Mittelhofen 11							
								72393 Burladingen 7		Zeichnungsnummer		Blatt 10			
								Telefon: 07126/929940							
								Telefax: 07126/9299-1		Vertrauliche Unterlagen		Blatt A3			
								Schutz DIN 34 beansprucht							
Zust	Änderung			Datum	Name			Baogr. .		Masch. FM250					

www.himel.de

- 3000538 FM60
- 3000539 FM120
- 3000540 FM180
- 3000541 FM250
- 3002183 FM300

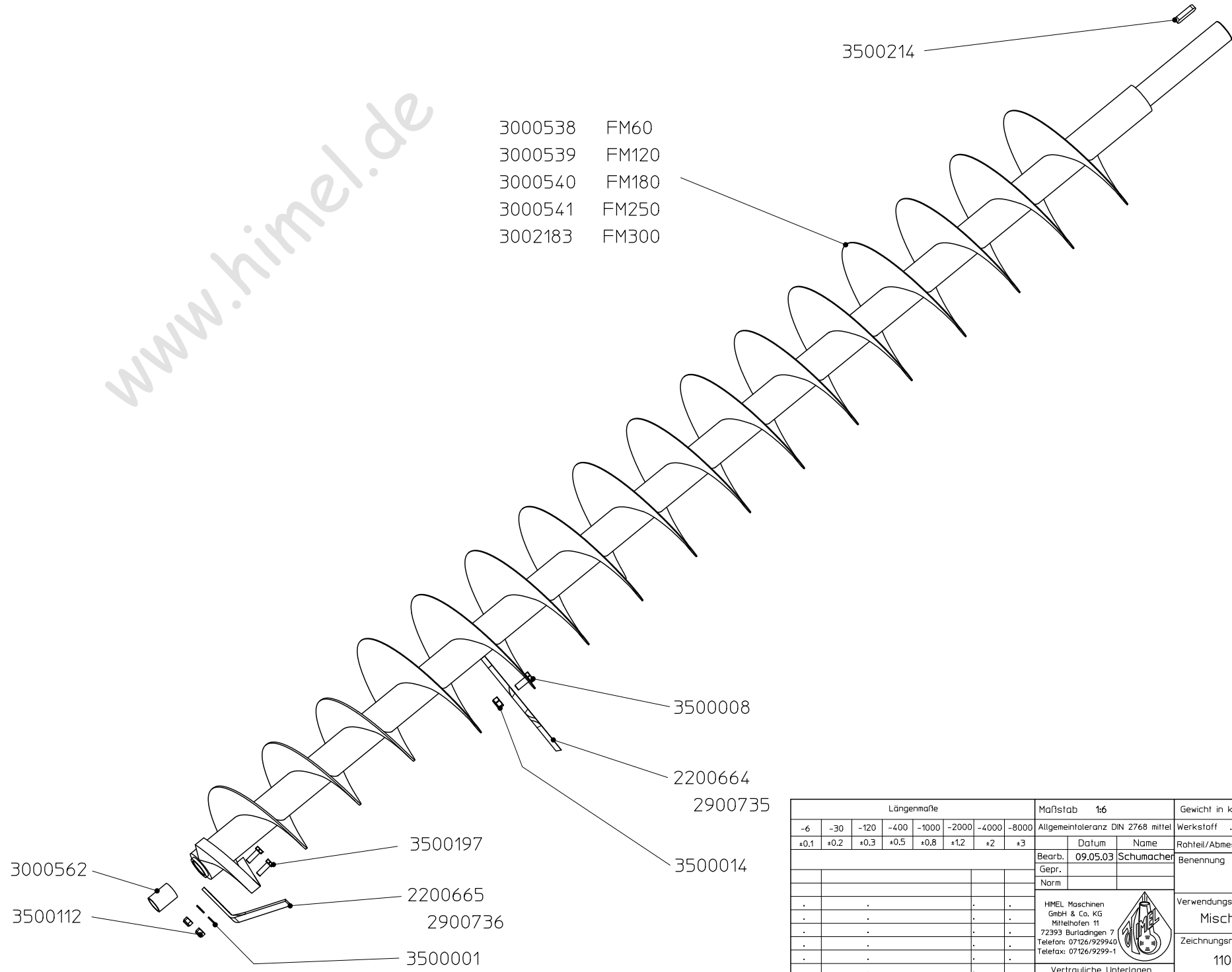

✓	✓	Rz100	.	.
✓	✓	Rz25	.	.
✓	✓	Rz6.3	.	.
Kanten entgratet		Paßmaß	Abmaß	

Längenmaße								Maßstab 1:6	Gewicht in kg ca. .	Stück.pro Maschine 1
-6	-30	-120	-400	-1000	-2000	-4000	-8000	Allgemeintoleranz DIN 2768 mittel	Werkstoff .	
+0.1	+0.2	+0.3	+0.5	+0.8	+1.2	+2	+3	Bearb. Datum Name	Rahteil/Abmessungen .	
								Gepr. Schumacher	Benennung	
								Norm	Ersatzteilliste	
								HIMEL Maschinen GmbH & Co. KG Mittelhafen 11 72393 Burladingen 7 Telefon: 07126/929940 Telefax: 07126/9299-1	Verwendungsbereich	
									Mischerschnecke kplt. FM60-FM300	
								Vertrauliche Unterlagen Schutz DIN 34 beansprucht	Zeichnungsnummer	
Zust	Änderung	Datum	Name						1100252-1100255+1100569	
									Blatt 12	
									A3	
									Baugr. .	
									Masch. FM60-FM300	

www.himel.de

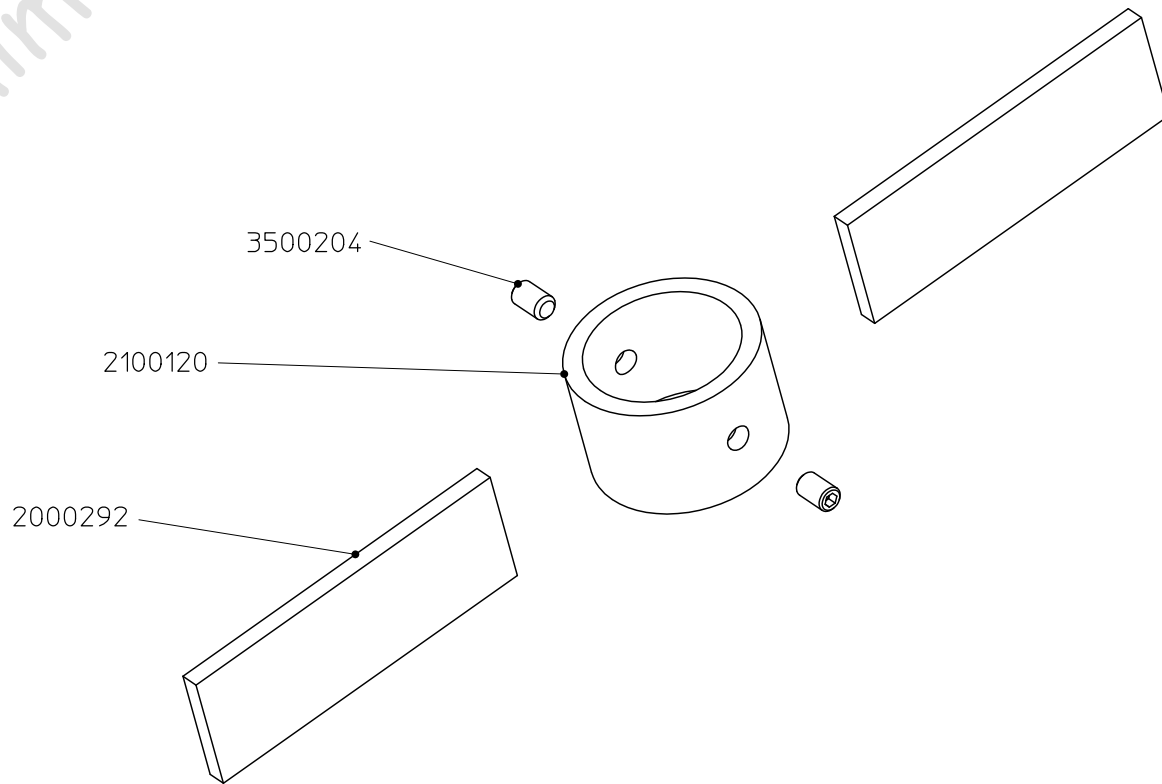

✓	✓	Rz100	.	.
✓	✓	Rz25	.	.
✓	✓	Rz6.3	.	.
✓	✓	Kanten entgratet	Paßmaß	Abmaß

Längenmaße								Maßstab 1:2			Gewicht in kg ca. .		Stück.pro Maschine 1	
-6	-30	-120	-400	-1000	-2000	-4000	-8000	Allgemeintoleranz DIN 2768 mittel			Werkstoff .			
±0,1	±0,2	±0,3	±0,5	±0,8	±1,2	±2	±3	Bearb.	Datum	Name	Rauteil/Abmessungen .			
								Gepr.		Schumacher	Benennung			
								Norm			Ersatzteilliste			
.	.	.	.	.	.	.	.	HIMEL Maschinen GmbH & Co. KG Mittelhafen 11 72393 Burladingen 7 Telefon: 07126/929940 Telefax: 07126/9299-1			Verwendungsbereich Verteilerflügel FM60-300			
.	.	.	.	.	.	.	.				Zeichnungsnummer		Blatt	
.	.	.	.	.	.	.	1100214				13			
Zust								Vertrauliche Unterlagen			Baugr. .		Masch. FM60-FM300	
Änderung								Datum Name			Schutz DIN 34 beansprucht			

1100478

2200668

2900737

2000291

3500064

3500084

3500014

2200669

2900738

1100479

2000291

2200668

2900737

3500014

3500084

3500064

3500064

3500084

3500014

www.himel.de

✓	✓	Rz100	.	.
✓	✓	Rz25	.	.
✓	✓	Rz6.3	.	.
✓	✓	Kanten entgratet	Paßmaß	Abmaß

Längenmaße								Maßstab 1:5			Gewicht in kg ca. .		Stck.pro Maschine 1	
-6	-30	-120	-400	-1000	-2000	-4000	-8000	Allgemeintoleranz DIN 2768 mittel			Werkstoff .			
±0.1	±0.2	±0.3	±0.5	±0.8	±1.2	±2	±3	Bearb.	Datum	Name	Rauteil/Abmessungen .			
								Gepr.	09.05.03	Schumacher	Benennung			
								Norm			Ersatzteilliste			
.	.	.	.	.	.	.	.	HIMEL Maschinen GmbH & Co. KG Mittelhafen 11 72393 Burladingen 7 Telefon: 07126/929940 Telefax: 07126/9299-1			Verwendungsbereich Zentralrohrbefestigung FM60-300			
.	.	.	.	.	.	.	.	Vertrauliche Unterlagen Schutz DIN 34 beansprucht			Zeichnungsnummer 1100209		Blatt 14	
Zust	Änderung	Datum	Name	Baogr. .			Masch. FM60-FM300			A3				



www.himel.de

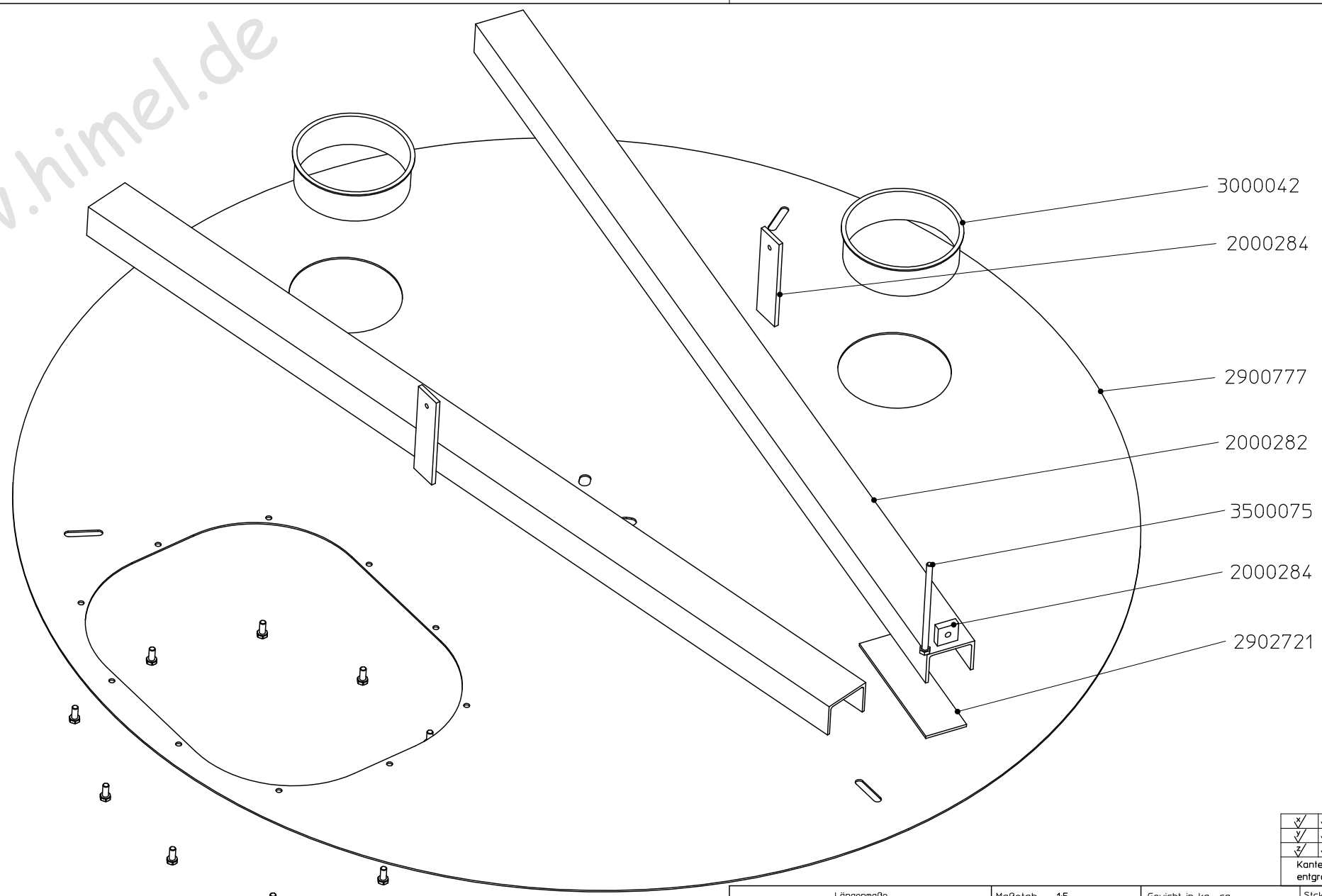

✓	✓	Rz100	.	.
✓	✓	Rz25	.	.
✓	✓	Rz6.3	.	.
Kanten entgratet		Paßmaß	Abmaß	

3500004

Längenmaße								Maßstab 1:5			Gewicht in kg ca. .		Stck.pro Maschine 1	
-6	-30	-120	-400	-1000	-2000	-4000	-8000	Allgemeintoleranz DIN 2768 mittel			Werkstoff .			
±0,1	±0,2	±0,3	±0,5	±0,8	±1,2	±2	±3	Bearb.	Datum	Name	Rahteil/Abmessungen .			
								Gepr.			Benennung			
								Norm			Ersatzteilliste			
								HIMEL Maschinen GmbH & Co. KG Mittelhafen 11 72393 Burladingen 7 Telefon: 07126/929940 Telefax: 07126/9299-1			Verwendungsbereich Deckel kplf. FM60-300			
								Vertrauliche Unterlagen Schutz DIN 34 beansprucht			Zeichnungsnummer 1100242		Blatt 15 A3	
Zust	Änderung		Datum		Name		Baugr. .		Masch. FM60-FM300					



www.himel.de

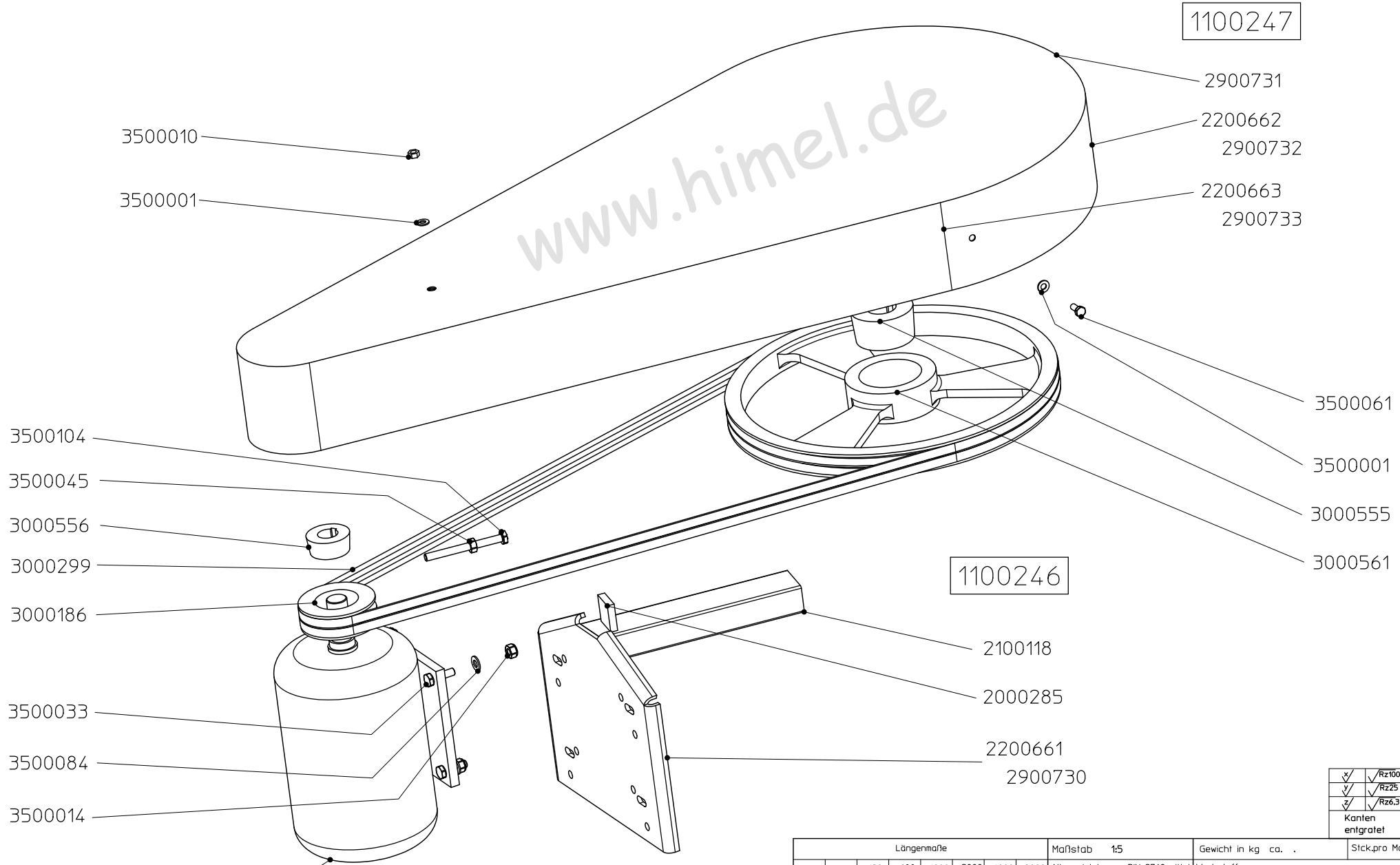

4000001 FM60  
4000002 FM120

✓	✓	Rz100	.	.
✓	✓	Rz25	.	.
✓	✓	Rz6.3	.	.
✓	✓	Kanten entgratet	.	.
		Paßmaß	Abmaß	

Längenmaße								Maßstab 1:5			Gewicht in kg ca. .		Stck.pro Maschine 1		
-6	-30	-120	-400	-1000	-2000	-4000	-8000	Allgemeintoleranz DIN 2768 mittel			Werkstoff .				
±0.1	±0.2	±0.3	±0.5	±0.8	±1.2	±2	±3	Datum		Name		Rauteil/Abmessungen .			
								Bearb. 09.05.03		Schumacher		Benennung			
								Gepr.				Ersatzteilliste			
								Norm							
								HIMEL Maschinen GmbH & Co. KG Mittelhafen 11 72393 Burladingen 7 Telefon: 07126/929940 Telefax: 07126/9299-1				Verwendungsbereich			
												Antrieb FM60-FM120			
												Zeichnungsnummer		Blatt	
								Vertrauliche Unterlagen				1100243-1100244		16	
								Schutz DIN 34 beansprucht				Baogr. .		Masch. FM60-FM120	
Zust	Änderung			Datum	Name										

www.himel.de

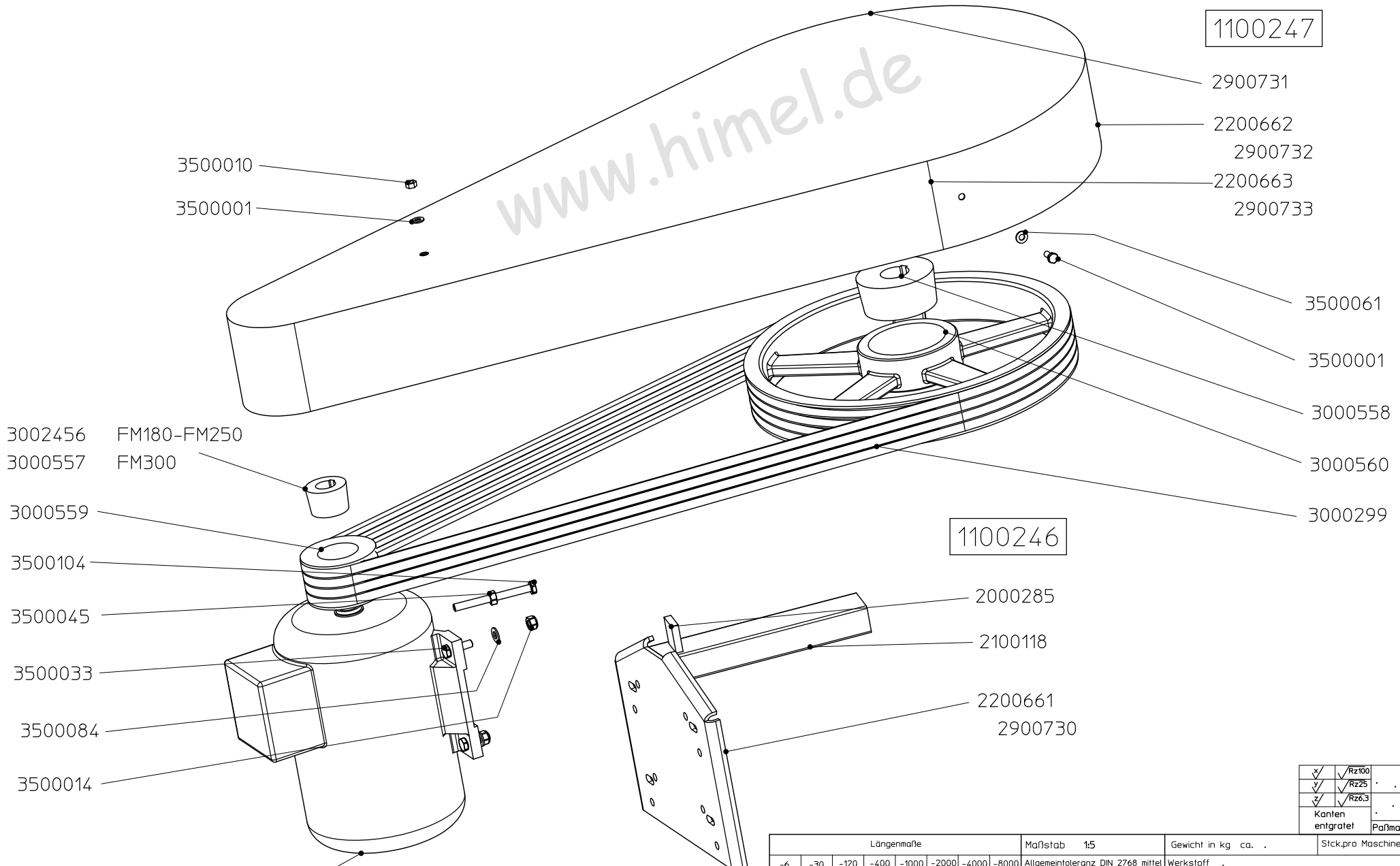

✓	✓	Rz100	.	.
✓	✓	Rz25	.	.
✓	✓	Rz6.3	.	.
✓	✓	Kanten entgratet	Paßmaß	Abmaß

Längenmaße								Maßstab 1:5	Gewicht in kg ca. .	Stück.pro Maschine 1
-6	-30	-120	-400	-1000	-2000	-4000	-8000	Allgemeintoleranz DIN 2768 mittel	Werkstoff .	
+0.1	+0.2	+0.3	+0.5	+0.8	+1.2	+2	+3	Bearb. 09.05.03 Schumacher	Rahteil/Abmessungen .	
								Gepr.	Benennung	
								Norm	Ersatzteilliste	
.	.	.	.	.	.	.	.	HIMEL Maschinen GmbH & Co. KG Mittelhofen 11 72393 Burladingen 7 Telefon: 07126/929940 Telefax: 07126/9299-1	Verwendungsbereich	
.	.	.	.	.	.	.	.		Antrieb FM180-FM300	
.	.	.	.	.	.	.	.		Zeichnungsnummer	
Zust	Änderung	Datum	Name	Vertrauliche Unterlagen Schutz DIN 34 beansprucht				Baugr. .	Blatt 17	
									Blatt 17	
									A3	
									Masch. FM180-FM300	

Ersatzteilliste

Antrieb FM180-FM300

1100245-1100567

Blatt 17 A3

Masch. FM180-FM300